

Illumination sources

Halogen
Xenon
Mercury
LED

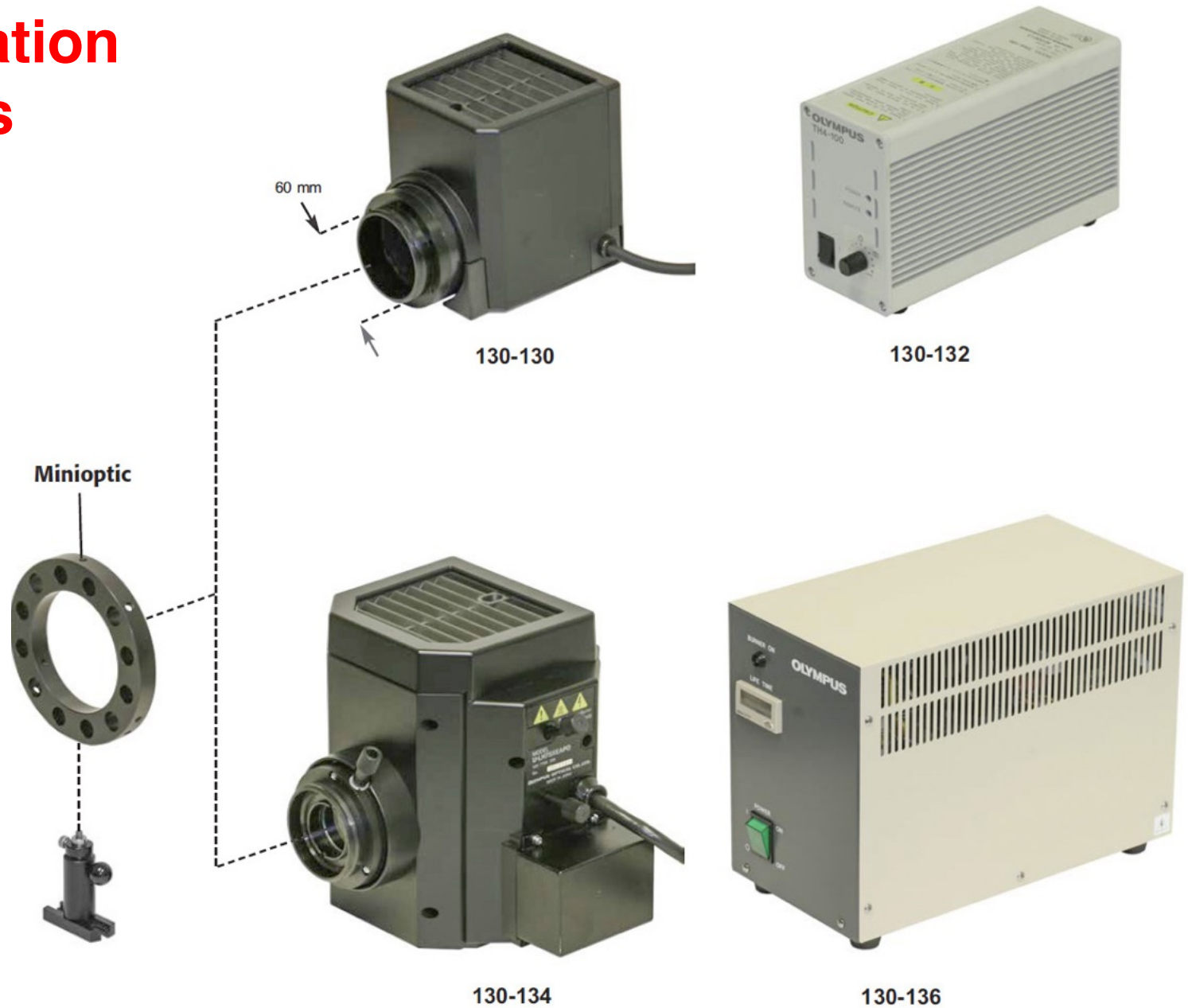

www.optoform.com

Compatibility of Olympus lamp housing with the Minioptic / Macroptic system.

ILLUMINATION SOURCES

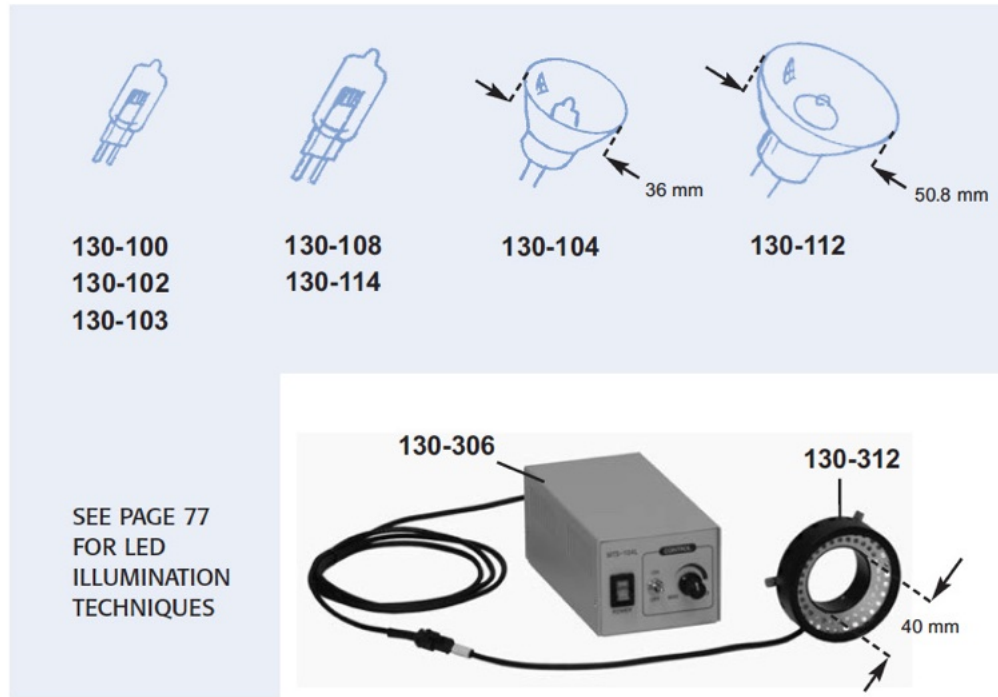

SEE PAGE 77
FOR LED
ILLUMINATION
TECHNIQUES



Halogen lamps come in several filament orientations (right). The Xenon lamps can not be turned on and off regularly to preserve its life (over 200 hours). The output is a constant intensity beam, with very high UV output. Our Xenon lamps are Ozone safe type. For Mercury lamp housing, and power supply see page 81.

| PART # | DESCRIPTION | |
|---------|------------------------|--|
| 130-100 | HALOGEN LAMP 6V/10W | For lamp socket 50-358 ,150 lumen , 2000 life hours 2.8 X 0.6 mm filament |
| 130-102 | HALOGEN LAMP 12V/20W | For lamp socket 50-358, 350 lumens, 2000 life hours 5.2 X 1.2 mm filament |
| 130-103 | HALOGEN LAMP 12V/35W | For lamp socket 50-358, 720 lumens, 2000 life hours, 3.3 X 1.5 mm filament |
| 130-104 | HALOGEN LAMP 12V/20W | WITH REFLECTOR for, 50-358,36 mm diameter 3000 life hours |
| 130-108 | HALOGEN LAMP 12V/50W | For lamp socket 50-359 2,500 l.h.5.6 X 1.6 mm filament |
| 130-109 | HALOGEN LAMP 12V/50W | WITH VERTICAL FILAMENT For lamp socket 50-359 2,000 l.h.5.6 X 1.6 mm |
| 130-112 | HALOGEN LAMP 12V/75W | WITH REFLECTOR, For socket 50-359. f=32 mm from the filament, 1,500 life hours |
| 130-114 | HALOGEN LAMP 12V/100W | For Olympus Lamp Housing 130-130, 5.6 X 3.0 mm filament |
| 130-116 | XENON LAMP 75W | Requires Olympus lamp housing 130-134. 200 lamp hours with daily use |
| 130-130 | LAMP HOUSING 12V/100W | Olympus lamp housing with 3 ft. cable connector. Minioptic compatible |
| 130-132 | POWER SUPPLY 12V/100W | Power supply for Halogen Lamp housing 130-130, 110VAC/C/60Hz |
| 130-136 | XENON LAMP HOUSING 75W | Olympus lamp housing with 3 ft cable connector. Minioptic compatible |
| 130-138 | XENON POWER SUPPLY 75W | Power supply for Xenon Lamp housing 130-134, 110VAC/C/60Hz |

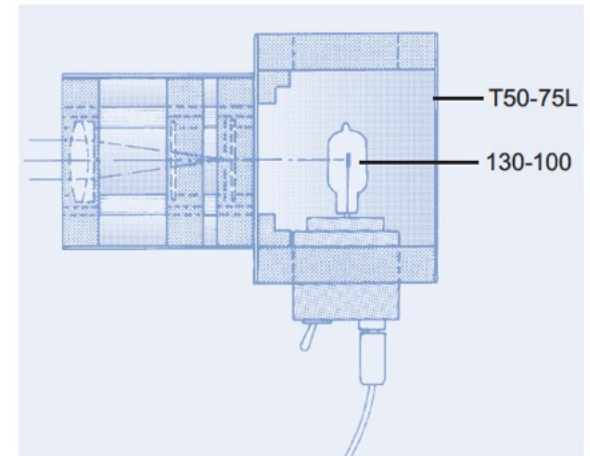
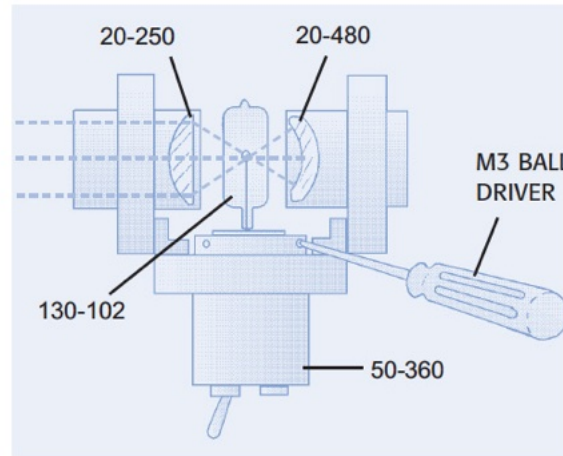
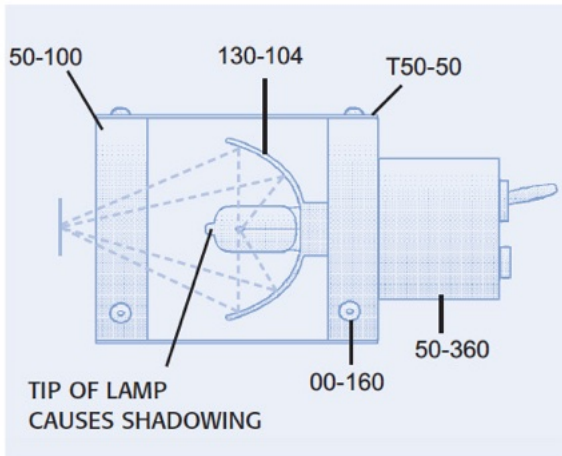
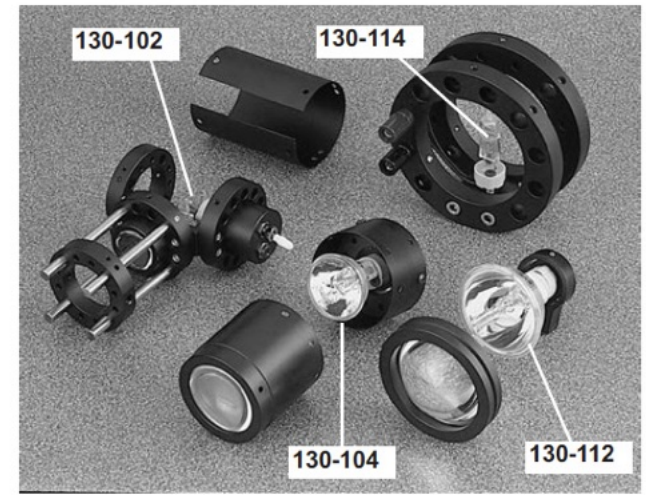

SPECIFICATIONS

| | |
|--------------------|---------------|
| Output Power | 2 mW |
| Wave Length | 635 +/- 10 nm |
| Beam Divergence | < 0.5 mrad |
| Operation Current | 50 mA |
| Operating Lifetime | 10,000 hours |
| Power Requirement | 5V DC |
| Weight | 2.7 OZ |

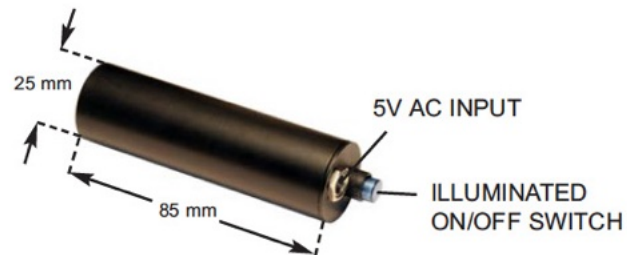

140-402 Laser Diode 25/2mW

140-402 is a 2mW compact self contained laser with circular beam shape. It is particularly suitable for integration within the Microptic and Micromax systems. Includes wall mounted 110V AC adapter.

LASER ILLUMINATION (OPHTHALMOLOGY APPLICATION)

In this laser eye surgery system, a laser beam is first delivered to the top of a vertical column via an optical fiber. Inside the column, a prism had to be rotated, and translated vertically for beam manipulation.

This arrangement calls for a combination of support rods and slotted tubing which would allow the user to control both vertical position and limited rotation of 50-172 from outside of the tubing.

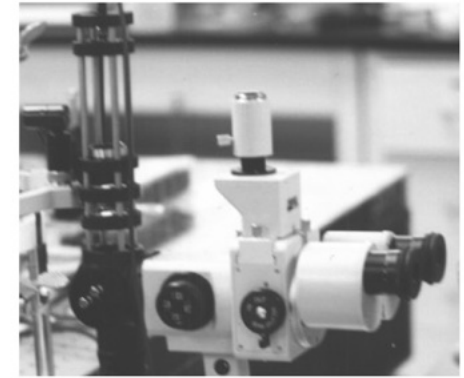
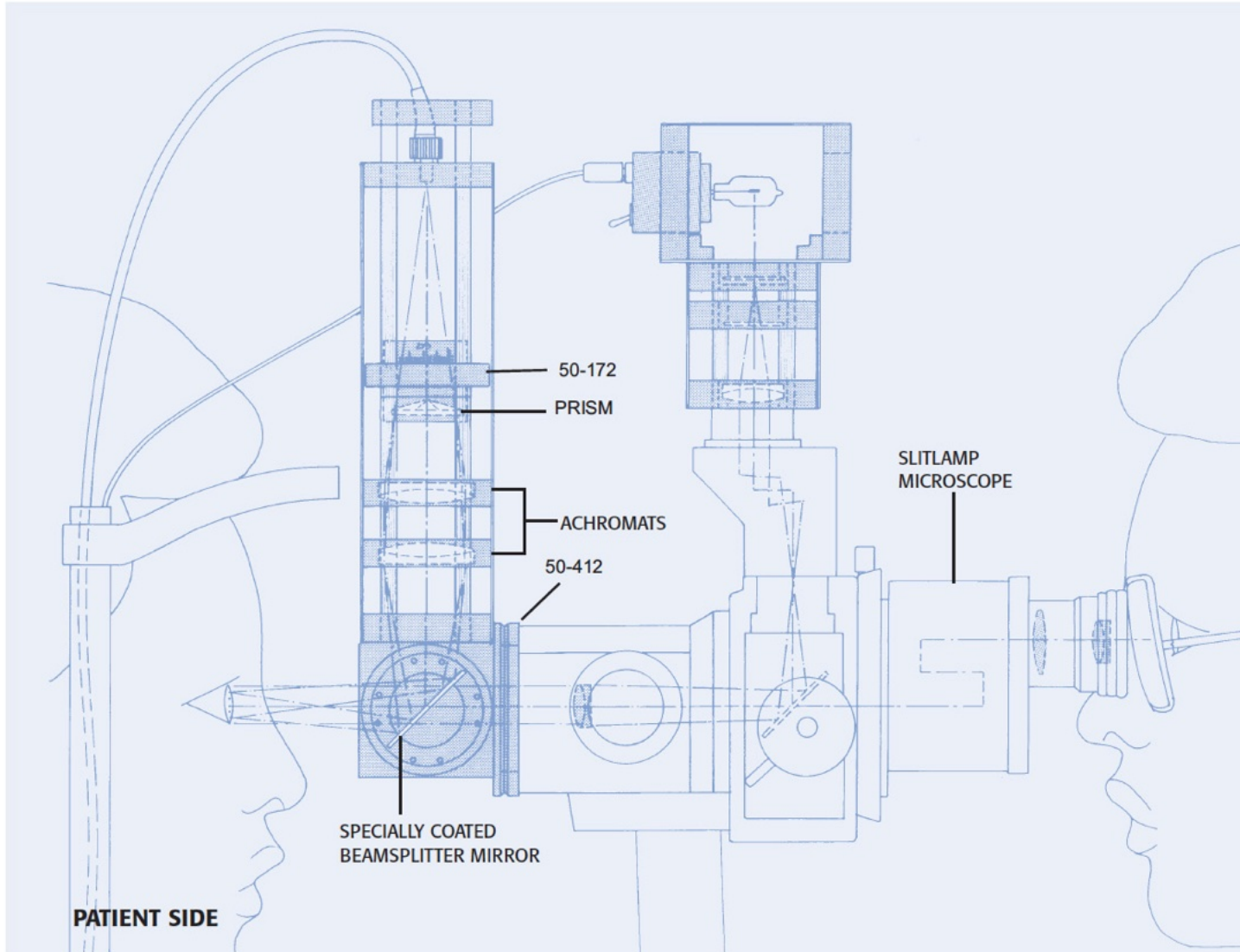

The interfacing of Optoform setups to slitlamp microscopes can be tricky. Most slitlamp microscopes such as Nikon shown, have a front barrel that can be clamped to microptic via 50-412. Mount 50-351 could also be mounted horizontally on top of ziesse instruments, etc. to provide additional support.

The pinhole projector (left) uses a halogen lamp, and an achromatic lens to project an image at infinity. When attached on top of a slit-lamp microscope, the X-Y stage is utilized to super impose the pinhole image with the laser spot, projected from the optical fiber. The patient is asked to stare at this spot to minimize his eye movement during surgery.

Linear bearings may be implemented by stacking the rotary mount (50-172), on top of a linear bearing plate 50-106.



Rear View



Frontal View

XFO Mercury Lamp Source with Light Guide, and Microscope Adapter

SFO light source is a well proven high intensity Mercury illumination source for Fluorescent microscopy, and FA microscopy applications where high resolution, high contrast imaging is in high demand. Lamp life is 2,500 hours, but many labs continue its use up to approximately 3,000 H.

The liquid-filled light guide gradually gets murky, after long use, and would need replacement every 5,000 hours (after two bulb replacements). The collimator has to be specified for Olympus, Leica, Zeiss, or Nikon.

| | |
|---|---------|
| SFO light box with light Guide, Mercury lamp, and Collimation Adapter | 130-146 |
|---|---------|

| | |
|--------------------------|---------|
| Replacement Mercury Lamp | 130-150 |
|--------------------------|---------|

| | |
|---------------------------------------|---------|
| Replacement Liquid Filled Light Guide | 130-152 |
|---------------------------------------|---------|

Lamp Release Lever



Spare Parts



Colomat Microscope Adapter



Mercury Lamp



Liquid Filled Light Guide



140-218 FULL AUTOMATION CONTROLLER WITH BUILT-IN POWER SUPPLY, CAPABLE OF CONTROLLING THE IRIS, DIC SETTING, ILLUMINATION.

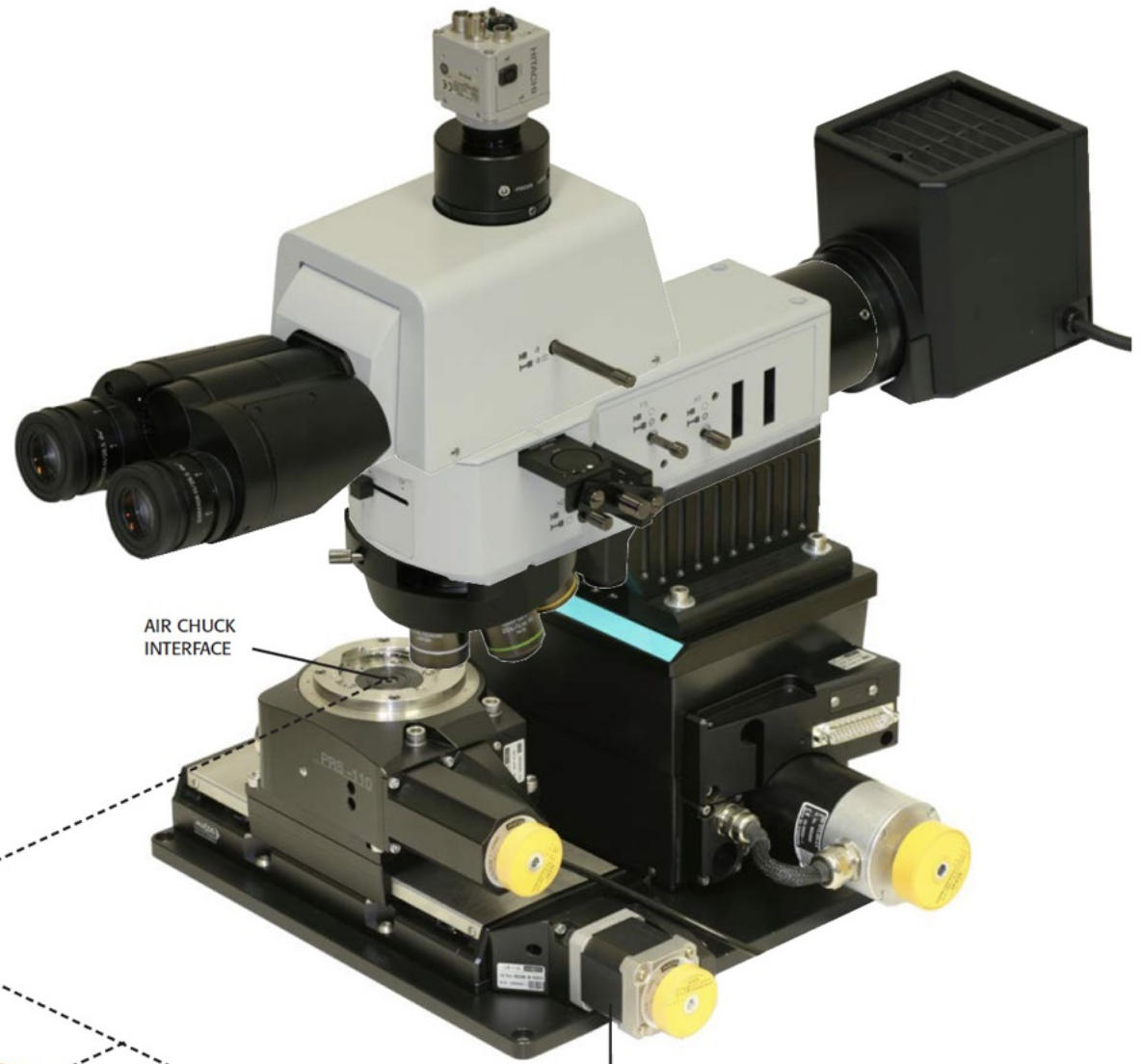

AIR CHUCK INTERFACE

MOTORIZED DISK POSITIONING ASSEMBLY

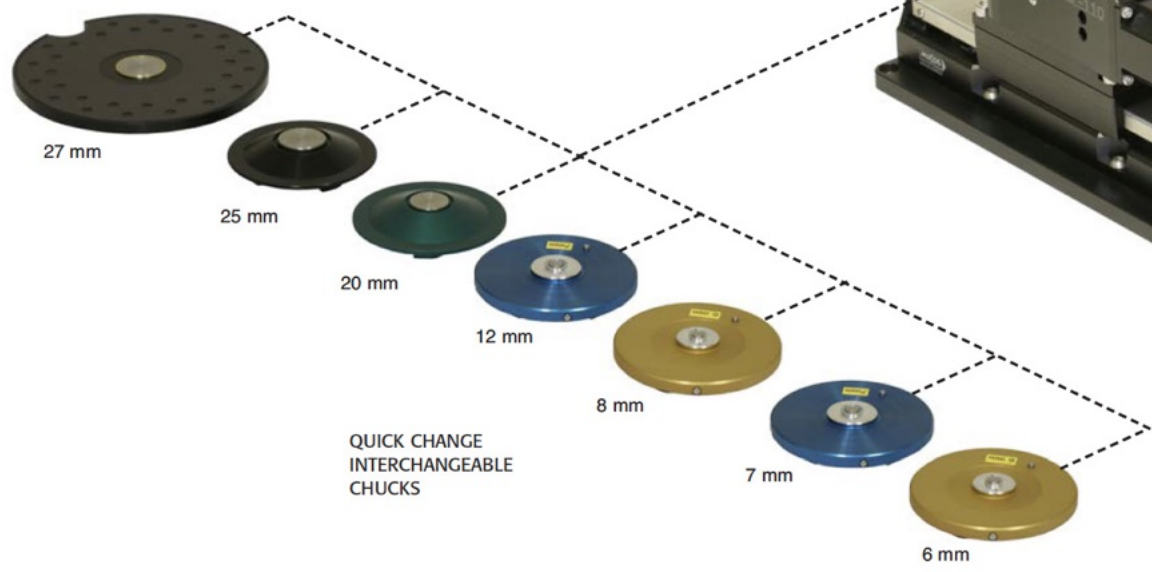

QUICK CHANGE INTERCHANGEABLE CHUCKS