

Optomechanix

Optoform 40 User's Manual

www.optoform.com

New Optoform II Cage System

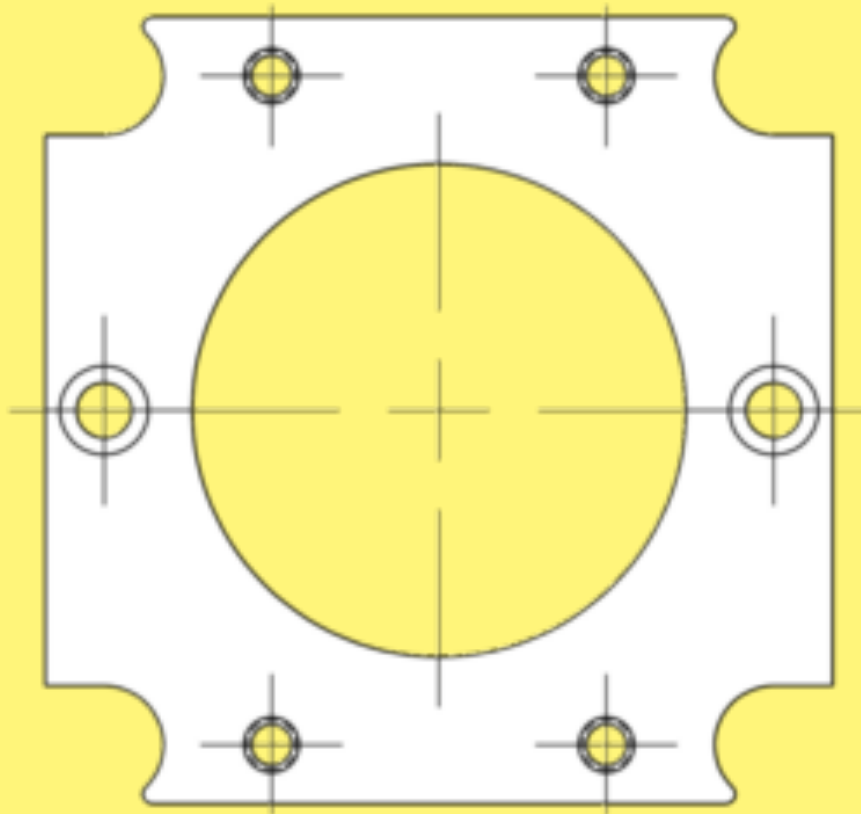

PCT Patent Pending US2019/020863
European WO 2020/180307, China 2021

Be Different. Think Different. Do it with Taste. Make it a better Product

A bit of History

For me, it all began by purchasing my first Microbench kits in late '80's, and I couldn't take my hands off it. But optical kits have been around since 1920's made by Alfred Carlton Gilbert who is known as the father of Erector Set.

Microbench

An optimized construction of a binocular head (right) with Microbench system built by author using minimum number of parts. I have always felt Microbench didn't succeed as much as its Thorlabs' counterpart was because it lacked an easy to understand user's manual for its end users. Microbench's use of corner connectors made it capable of solving far more complex problems than its simplified Thorlabs counterpart.

In Optoform II concept, support rods act as corner connectors. We'll build a binocular head with Optoform II to compare its flexibility, and cost.

Optoform I

I invented, and filed a PCT patent for Optoform in 1993, hoping to offer a lower cost system than Microbench. Right, a motorized Biological binocular microscope built with original Optoform utilized concentric circular building blocks from 25 to 150 mm in diameter.

The capabilities of Optoform have been known by many research centers, and universities around the world. Complex optical cage systems are difficult to get started with, but those who do master it, can't live without it. Optoform I is still one of the most versatile erector sets offered to optical engineers, and optics lab technicians alike.

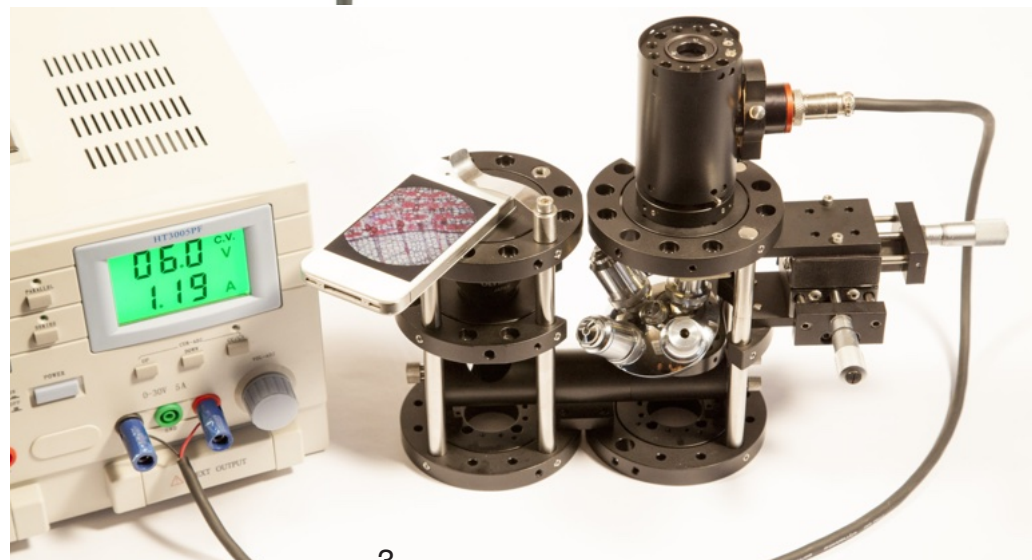
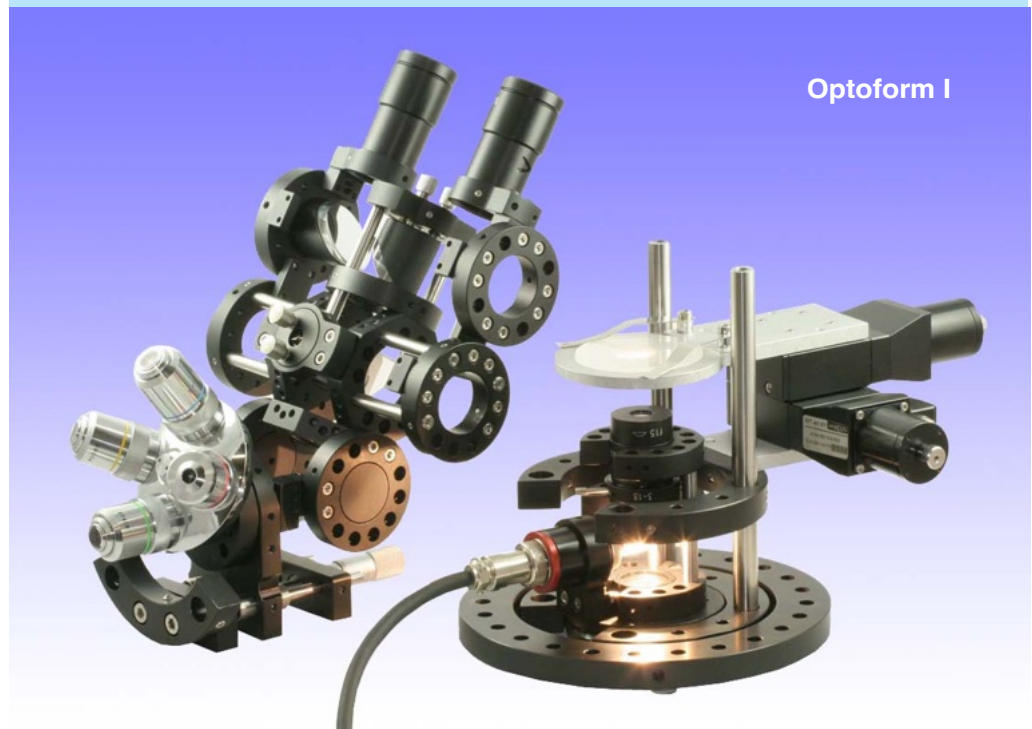
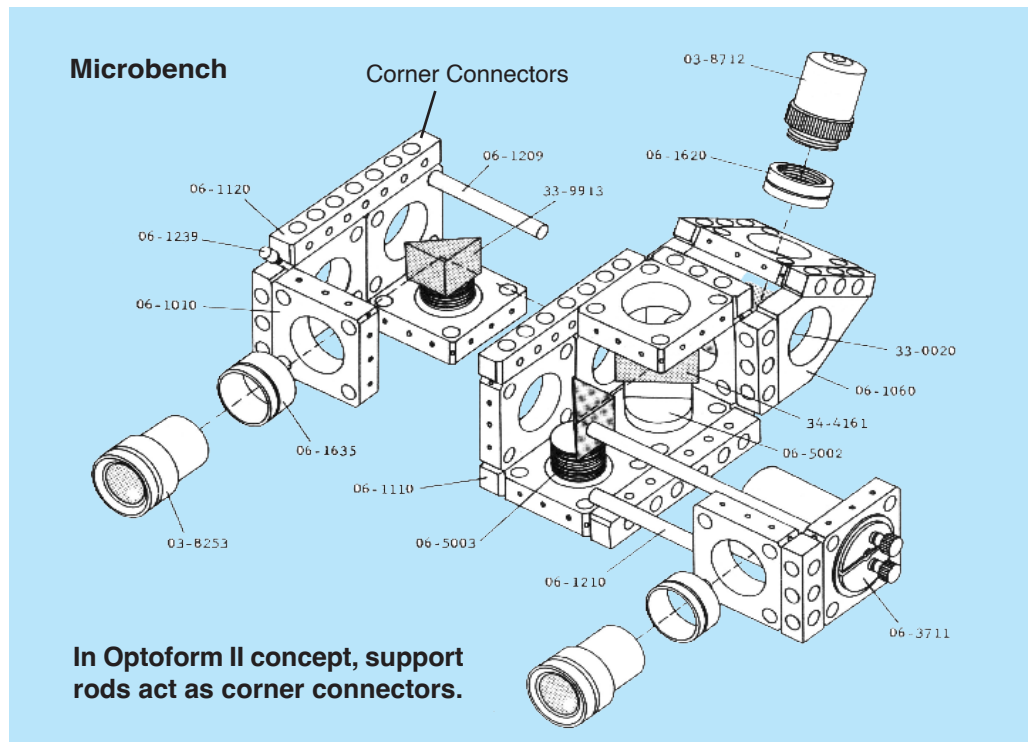



We have come a long way with Optoform II The new generation of optical Cage System

When visiting trade shows, and observing so many new products, I have often offended some sales people by telling them their product isn't genuine. An optical cage system should bring something new, and honest to its end users. If you think you could just take off one rod, or change anodization colors, people will say no to it. Although a one-rod or three rod cage system is not as good as a 4-rod arrangement that's an engineering decision, not an innovative one.

So after nearly 30 years past my original design of Optoform in 1993, I said Optoform II better be something phenomenal or I won't spend time on it. Luckily, the new idea I had about making them cheaper, and more versatile, led me to design a new form that could be produced out of extruded Aluminum - a drastic reduction in manufacturing cost.

Before signing off an M&A agreement with Edmund Optics to hand over Optoform I, we had been manufacturing it for 18 years. I know it takes a 5-axis CNC machine around 5 minutes to produce each mount. This drives the price to \$30 each. New Optoform II can be produced in about half that time, and half the cost.

Since Optoform II is less expensive, thinner, and lighter, you could divide your setups into sub-assemblies. Optoform II offers space frame components so you could build complete housings, and portable instruments. In upcoming pages, we'll review some real applications, and see how the new Optoform building blocks can be helpful in constructing them. These are culmination of many applications notes previously published in our quarterly magazine at optomechanix.org.

Ali Afshari
CEO, Optomechanix

Main Design Advantages: Less expensive, more versatile, more compact, lighter weight, more rigid, accepts larger optics, allows assembly from modules, could use various size rods.

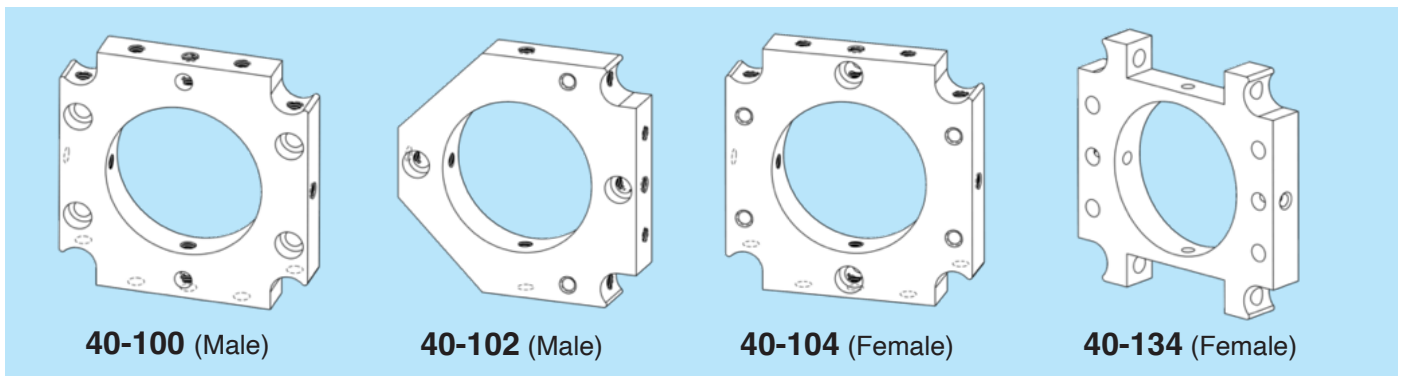

Standard Optoform mounts include 40-100, and 40-104. These 40x40 mm mounts can be mounted face to face, and side by side.

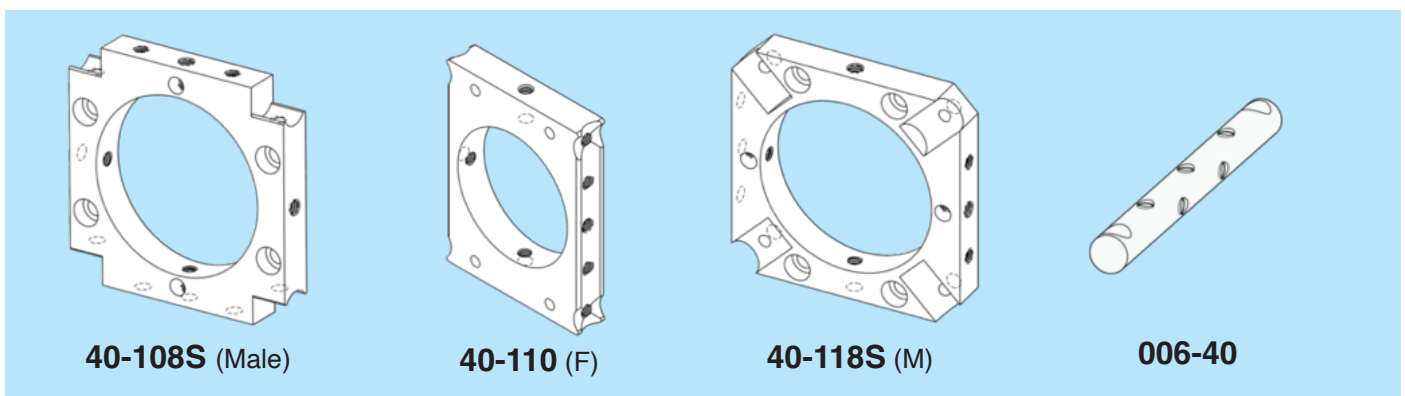

More advanced mounts can secure rods in diagonal direction, or be mounted in-line against support rods (right).

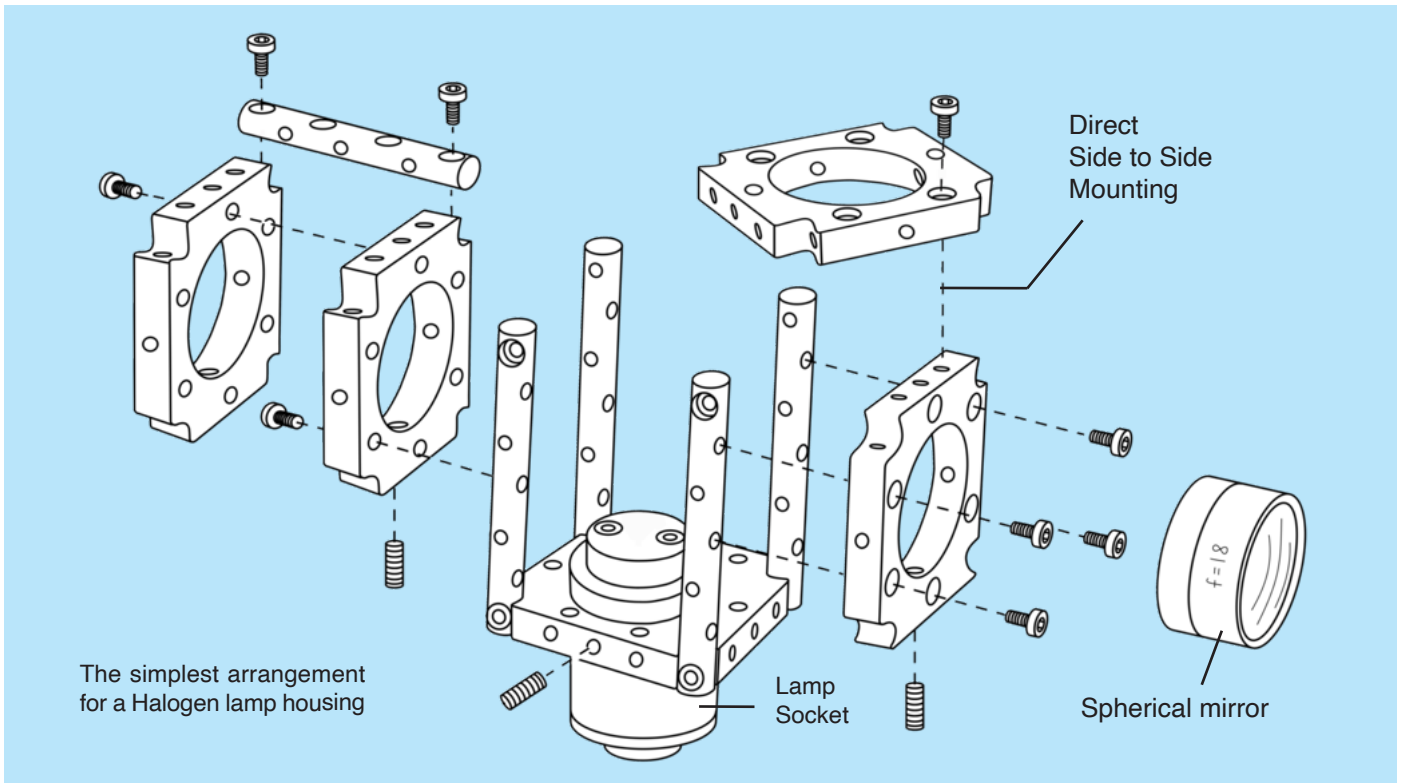

Everything you build is a module that can combine with other modules to build your setup.

Here's the first example: Various size halogen lamps can be centered by using proper length of rods to center the filament with the condenser optics (above). For short stroke focusing of optics, we'll be using the mounted lens cell itself for focusing. If the application requires a longer focusing range, we could also focus along the rods. There is a threaded bore pattern along the rods that allows multiplicity of interconnects between modules. Below is an alternate method to construct the same lamp housing.

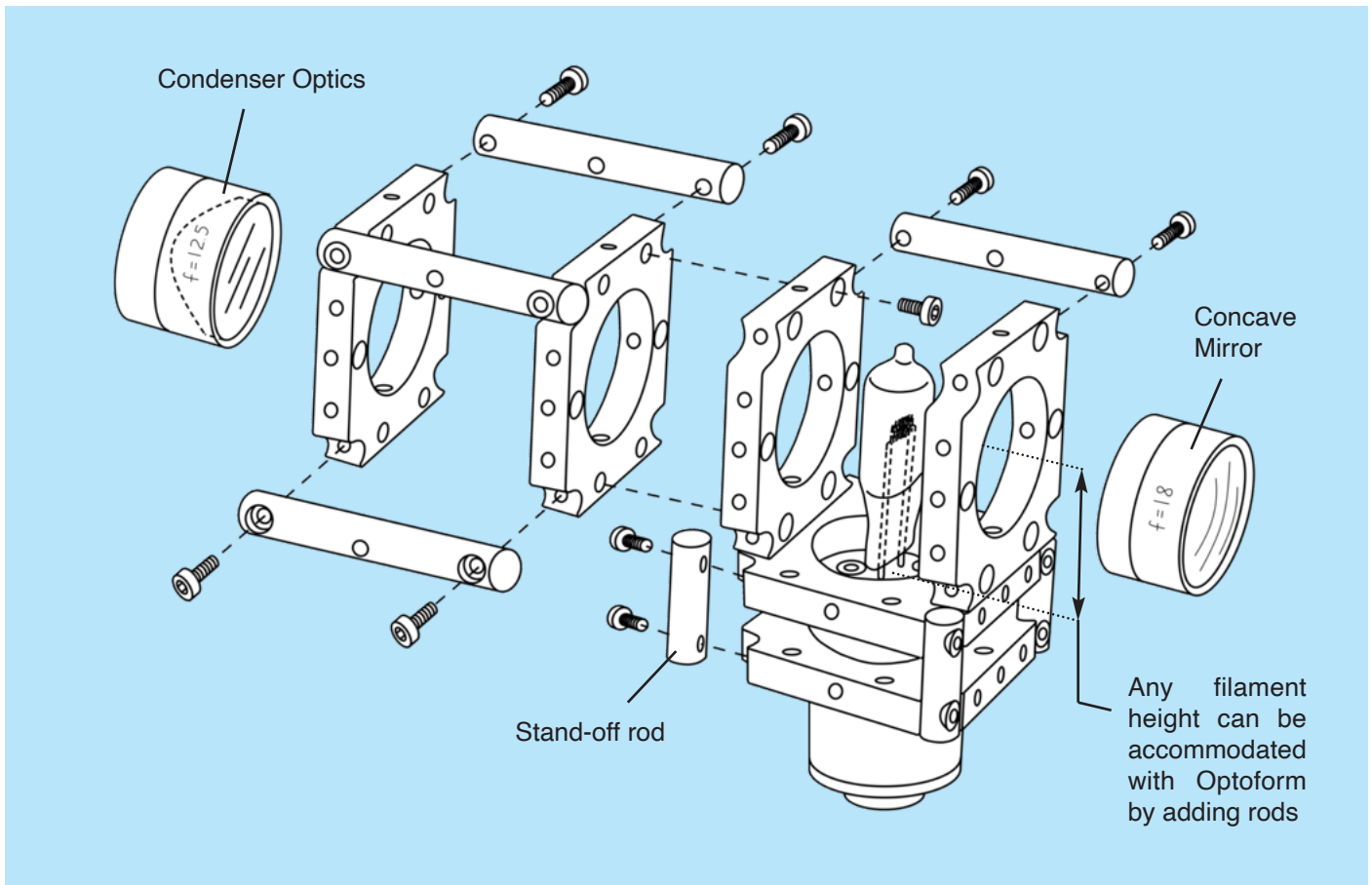

When designing Optoform modules, some basic guidelines may be considered:

1) Anything less, then it wouldn't be functional

That's the philosophy I try to follow in module design. For those who have mathematical minds, a module is like an optimized equation. Once you simplify an equation to its minimal form, then you could save it, and use it anytime later.

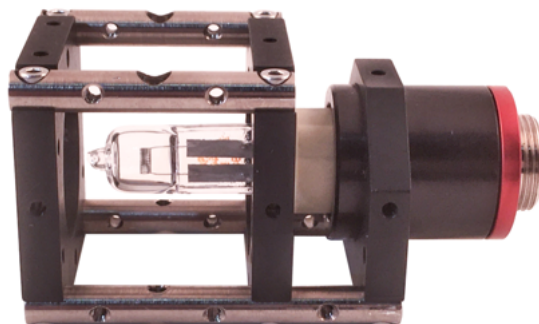
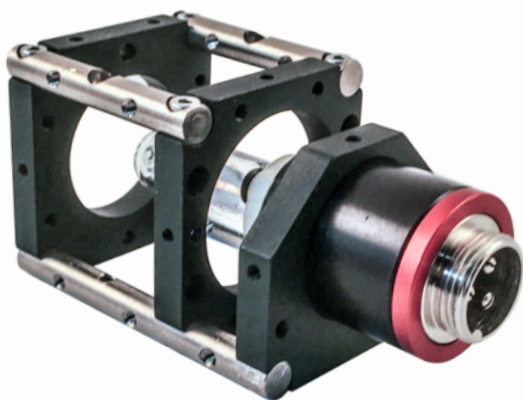

2) Modules should allow chain connections / All screws accessible

It's usually a good idea to have male on one end, and female on the other as shown in short rod assemblies below.

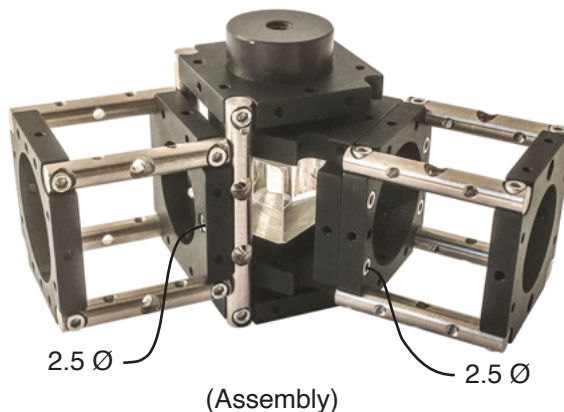
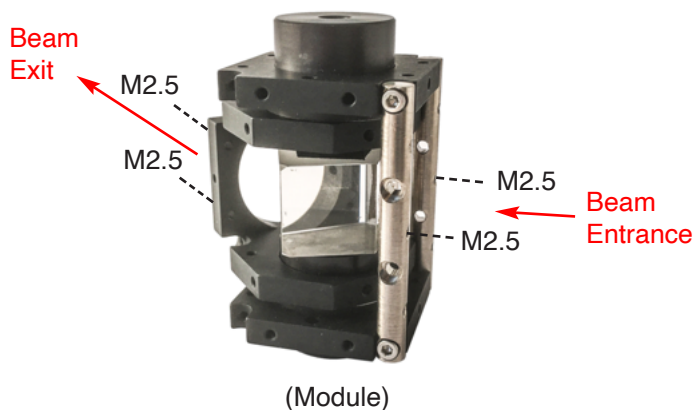
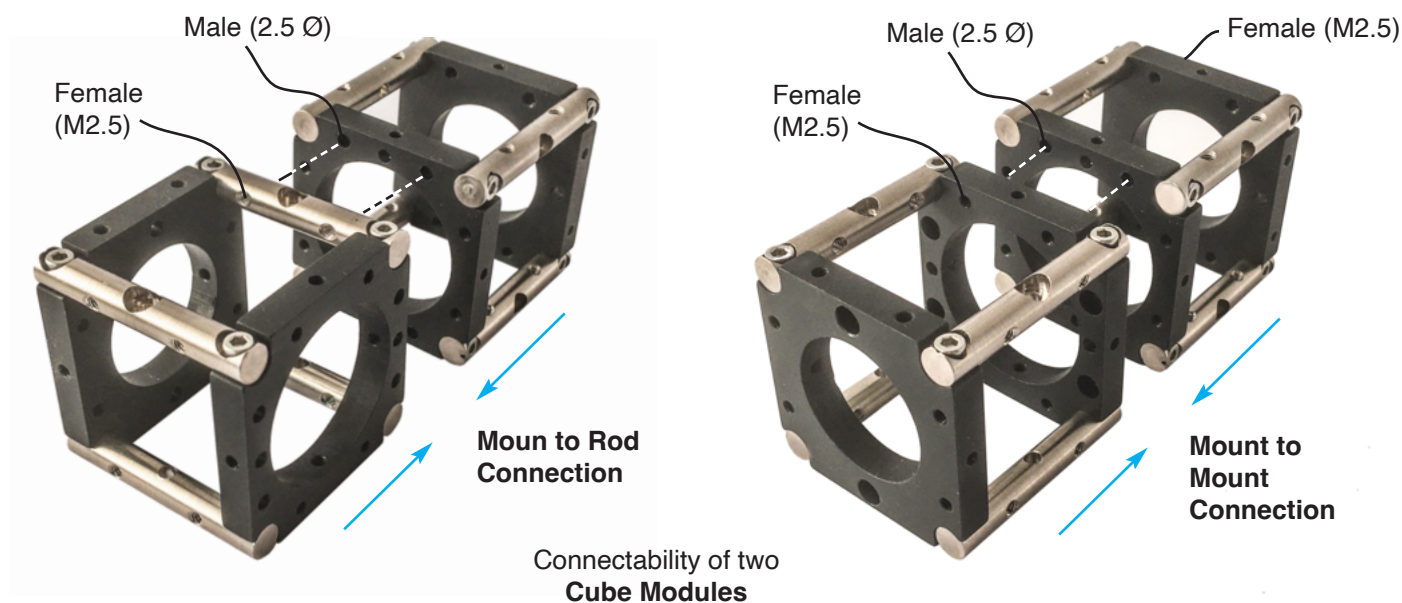

Two cubes could be attached to the input/output of **Swivel module** (left) via M2.5 screws to build a spectroscope (right).

Building Modules From Discrete Parts

I will show you an example how to build an opto-mechanical assembly such as an autocollimator using a light source, an eyepiece, a focusable target, a beamsplitter, and an objective lens. Instead of starting with a central piece like the beamsplitter assembly, and adding components around it, we'll begin by constructing modules by picking different lengths of rods, and we'll combine them together later.

Lets build the halogen lamp first: Halogen lamps come in different filament heights, and could pick the appropriate rod length to center the filament, and then fine adjust it by sliding its socket within the mounting plates (below). The collimation optics consists of a concave mirror, and an Aspherical condenser lens. We could add 25 mm tubing to each lens to focus them to the filament. Then there are more elements to add such as the target with perhaps a diffuser. The beamsplitter, and the eyepiece could then be added.

Adding them all together, the filament is focused on the objective lens surface. A flat mirror is usually placed in front of the objective lens, and the target is focused so that its image would fall on itself through the eyepiece. The beamsplitter angle, and the eyepiece is then adjusted to center, and focus onto the target.

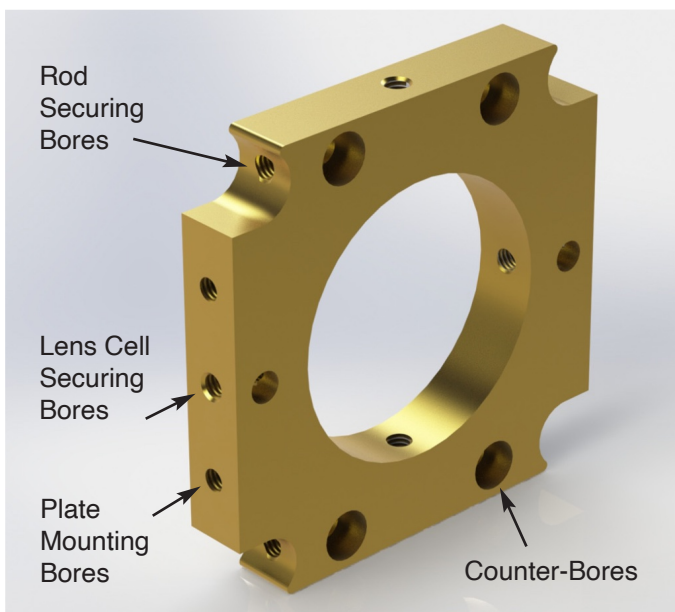

Threaded bores on the sides, and counter-bores on the plates allow direct mounting of mounts at right angles.

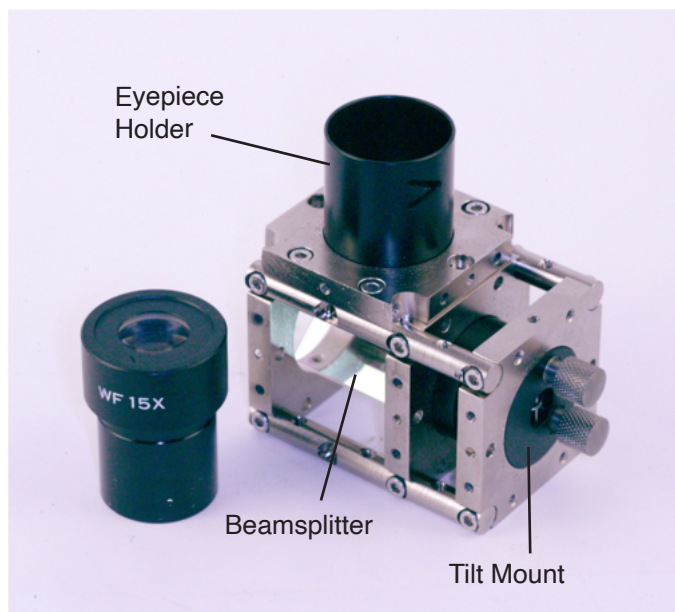

Thinner mounts means you could fit more components in a smaller package like in this beamsplitter assembly.

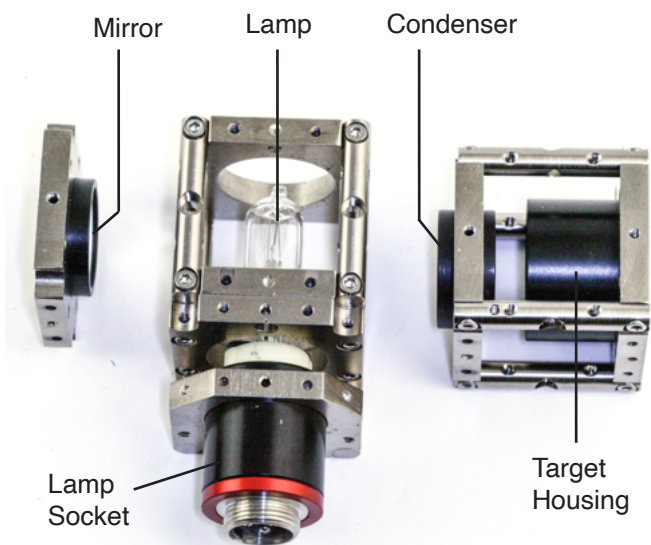

The mounts may be secured on side of rods to construct this illumination assembly for a Halogen lamp.

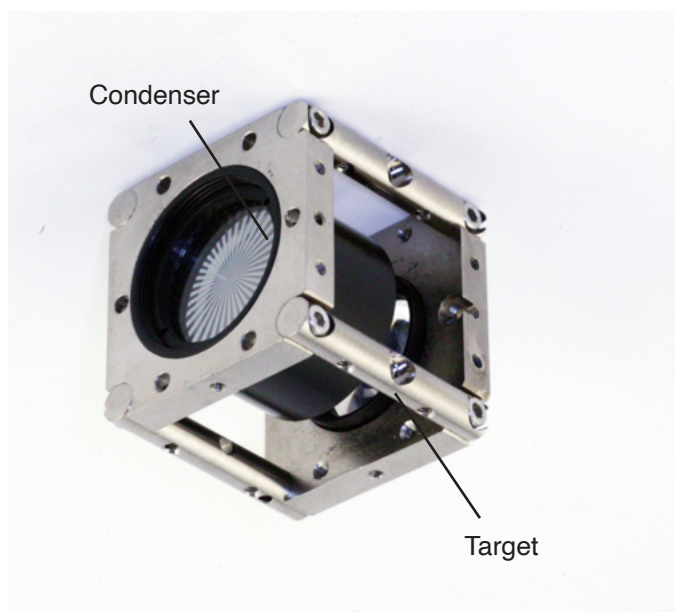

Here is an example of adjusting the position of elements within the mounts to build this target illumination optics.

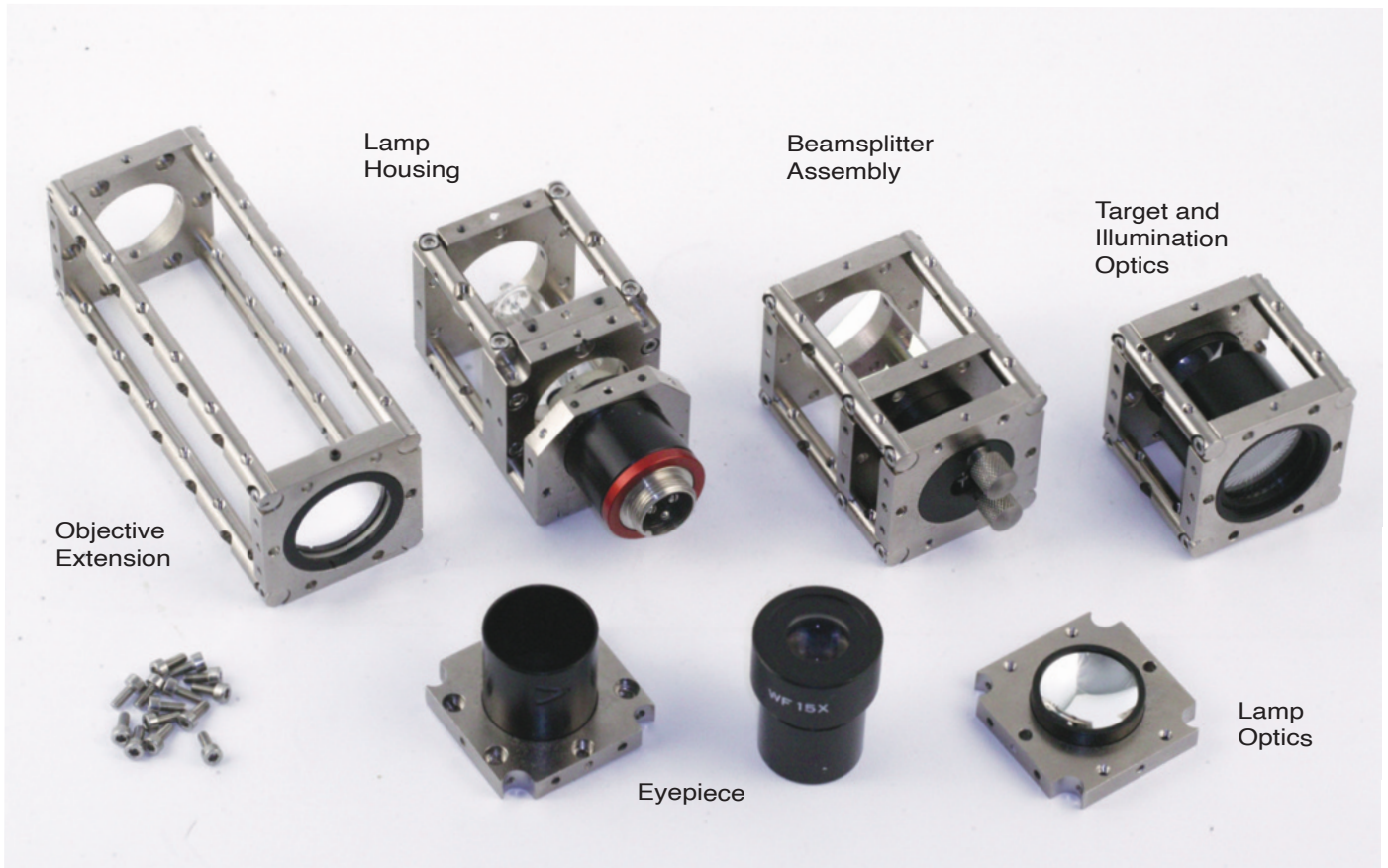

Build the modules you need first, don't worry, you'll have plenty of ways to combine them together in your setup: You could attach mounts along the rods, across the rods, and in many other ways.

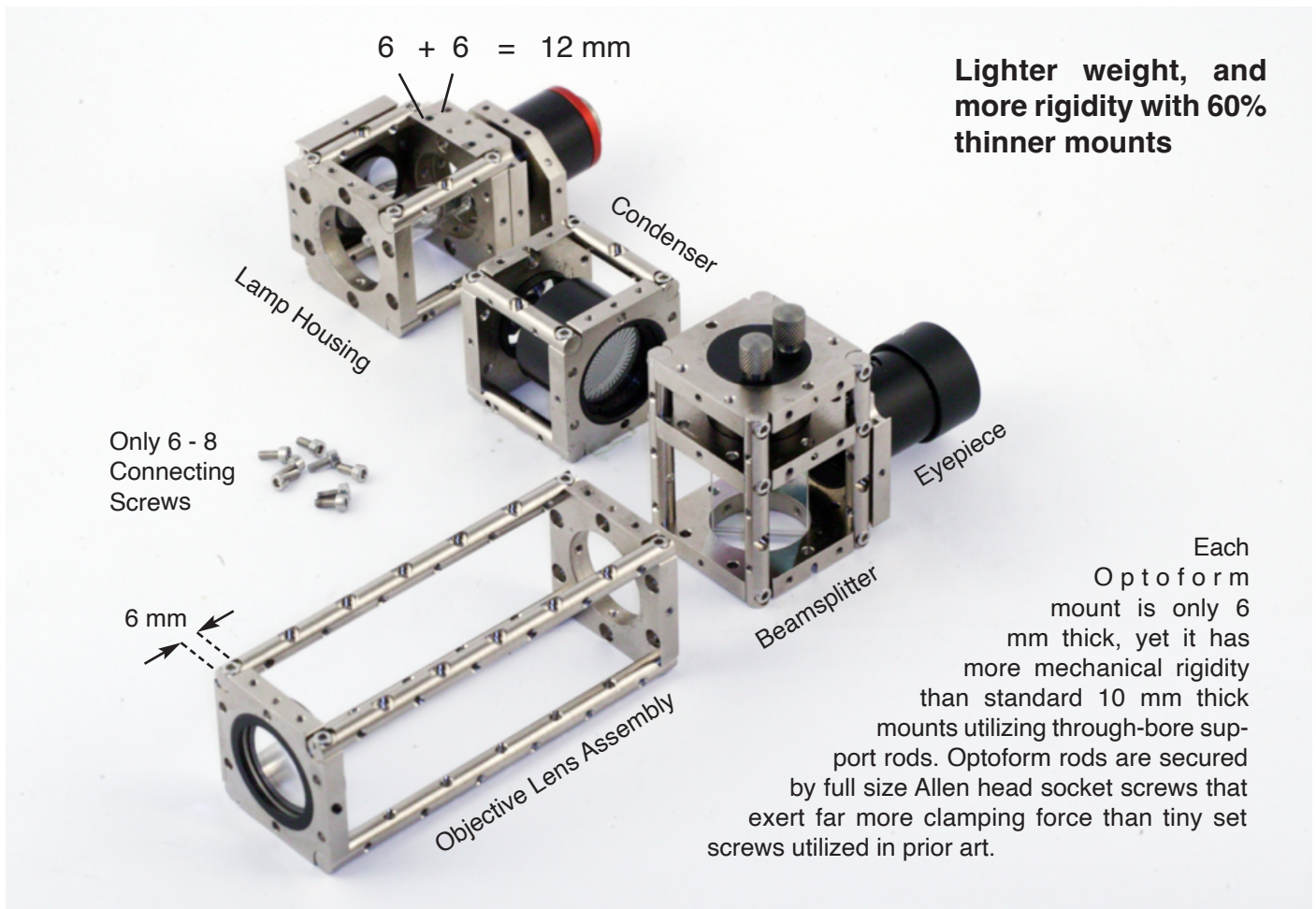

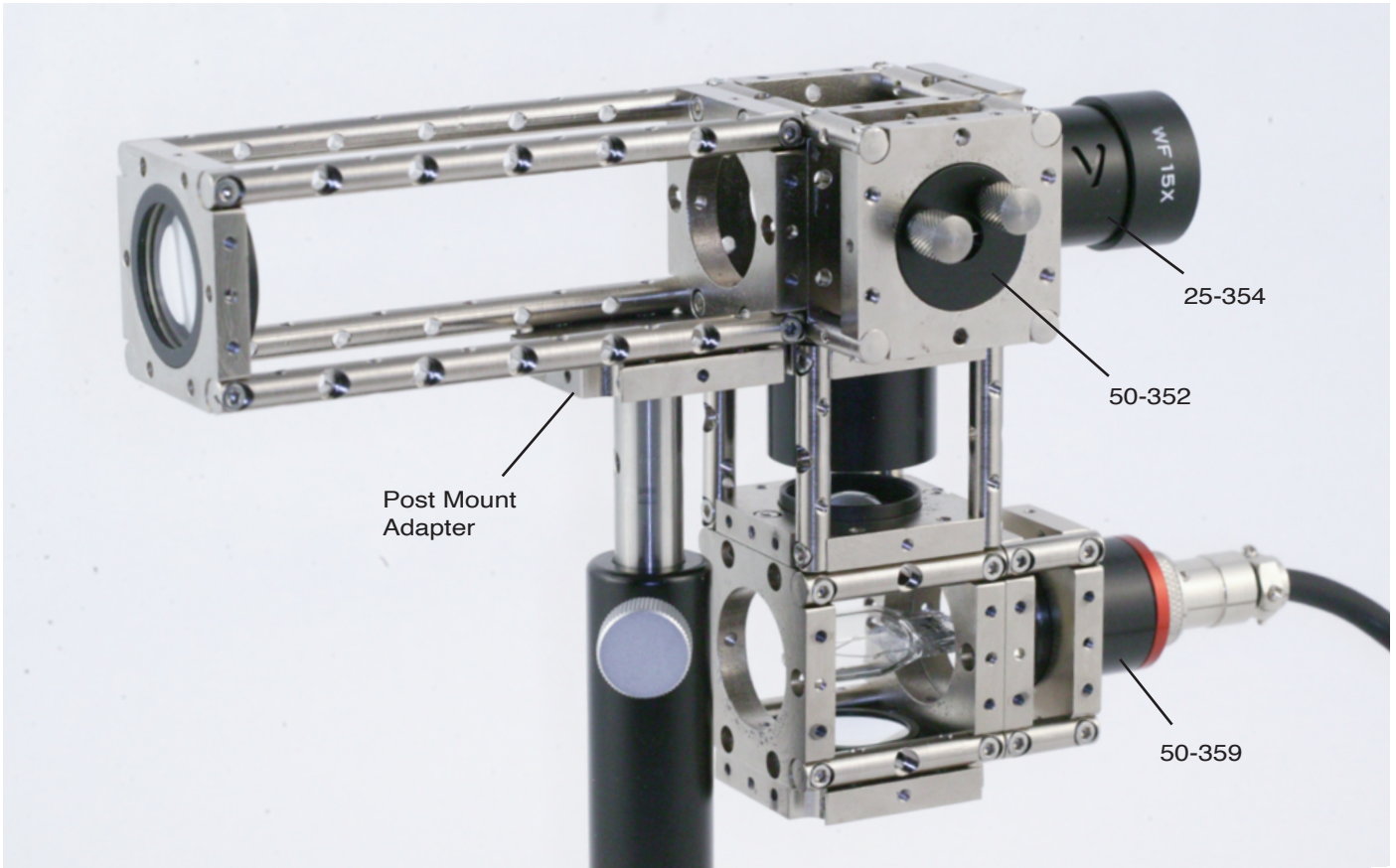

The fully assembled autocollimator on a post mount. Bore pattern on rods simplifies opto-mechanical interconnections. Instead of predictable assembly routines, Optoform II would stoke your imagination, and empower your creativity.

Opto-Mechanical Rigidity

Optoform has always been a “Whole Setting Concept” than being limited to only one size. Shown below, it could step up in size to build a complete sensor housing. All mounts offer direct upward / downward compatibility. All standard mounts (i.e., 40, and 74 mm square) are 6 mm thick, and utilize 6 mm rods. But how is this possible?

The clamping force in Optoform rods is by full size Allen cap screws. This provides far more rigidity than set screws utilized in prior art. The skeleton structures are further reinforced by pre-fabricated Aluminum covers (right).

The fact that these mounts are 40% thinner allows one to add interface plates (male/female) so the modules could come apart without losing their own identity as sub-assemblies. This also demands higher structural rigidity, and flatness between the mount, and the rods.

To make this work, sometimes it is necessary to logically follow through the final structure, and loosen, and tighten some of the rods to make sure there are full contacts between the joints. At the micron-level, the structure itself would shift towards a solid / wobble-free, self holding support frame.

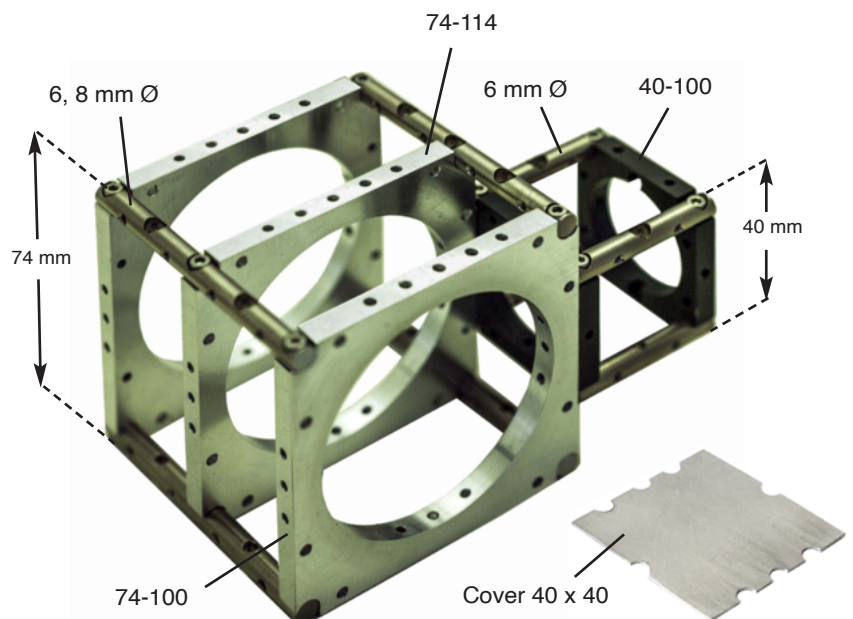

Microscope Housing with a Single Detector

A comparison between building with machined parts vs Optoform

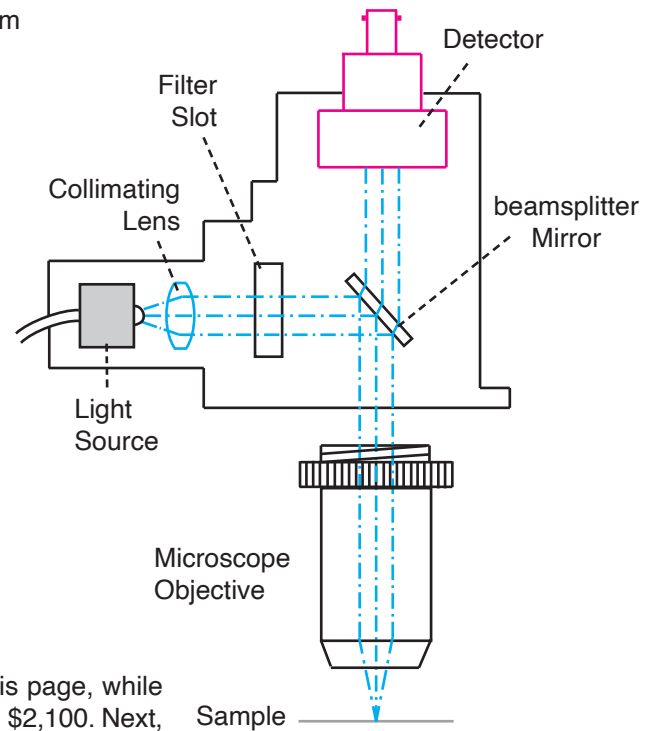

A scanning microscope is built with machined parts shown on this page, while not being able to change the final assembly. Total cost for housing \$2,100. Next, the same assembly is built utilizing off-the-shelf Optoform components. It's 50% lighter, and the final design can be rearranged. Total cost of housing \$325.

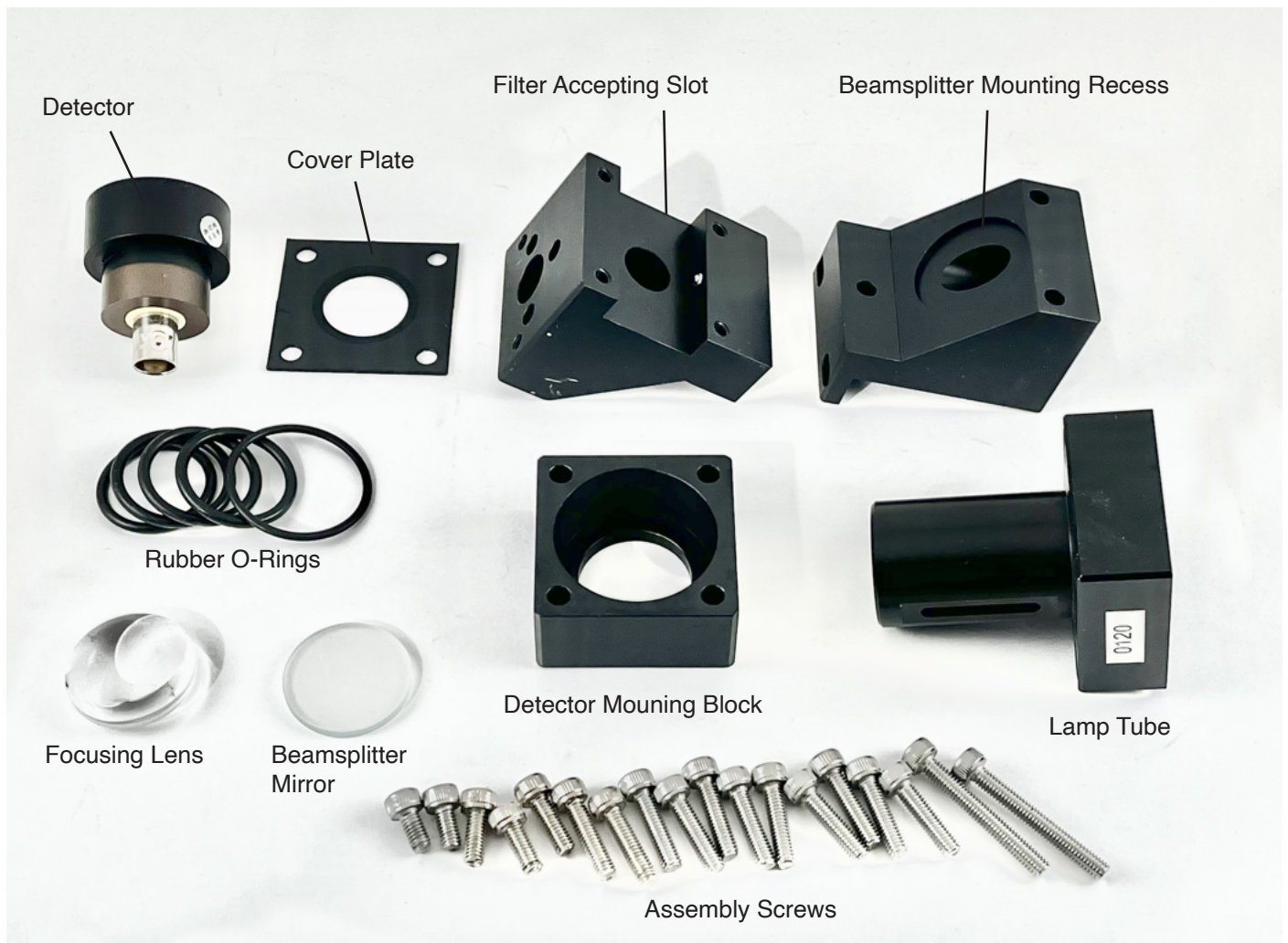

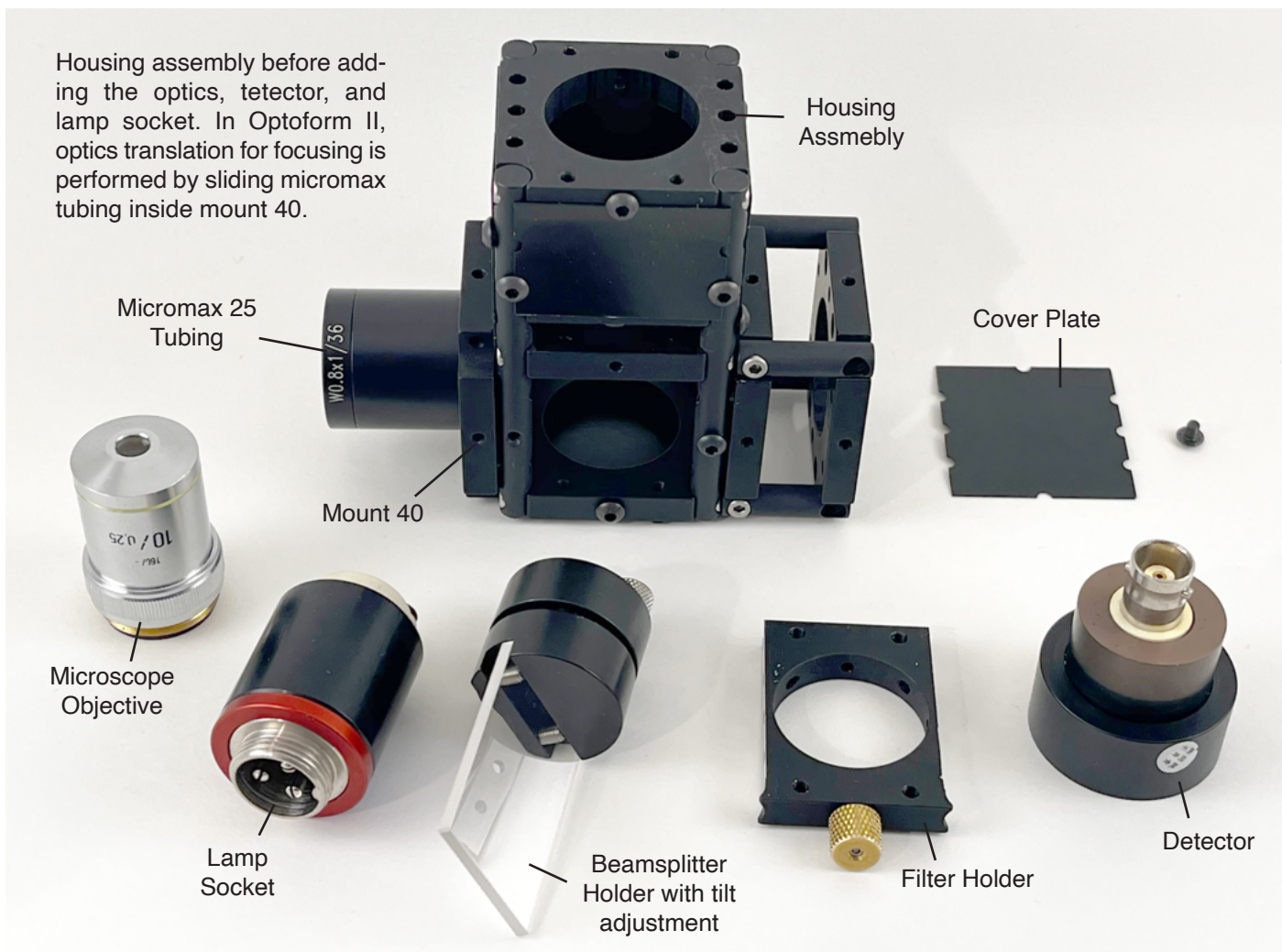
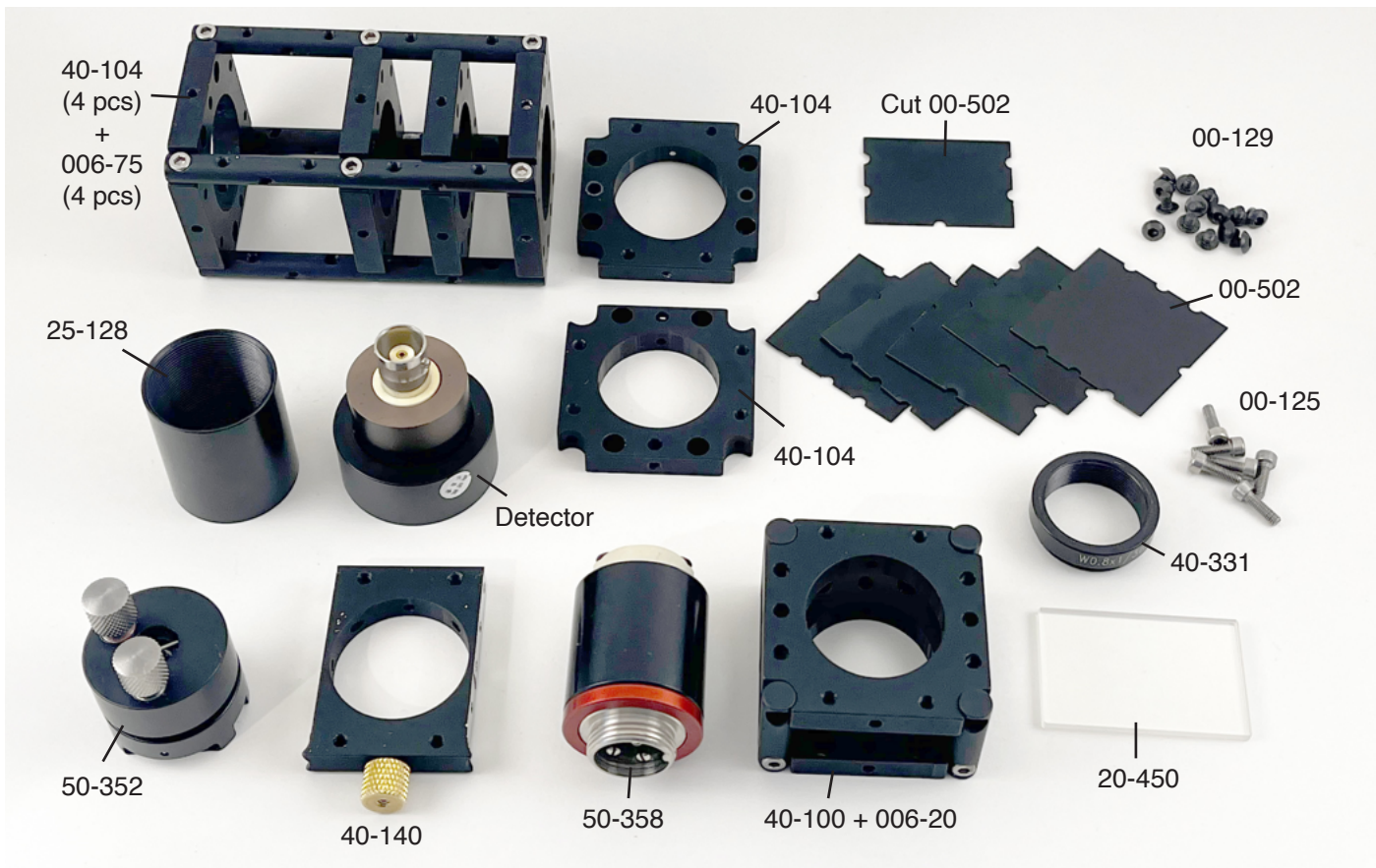

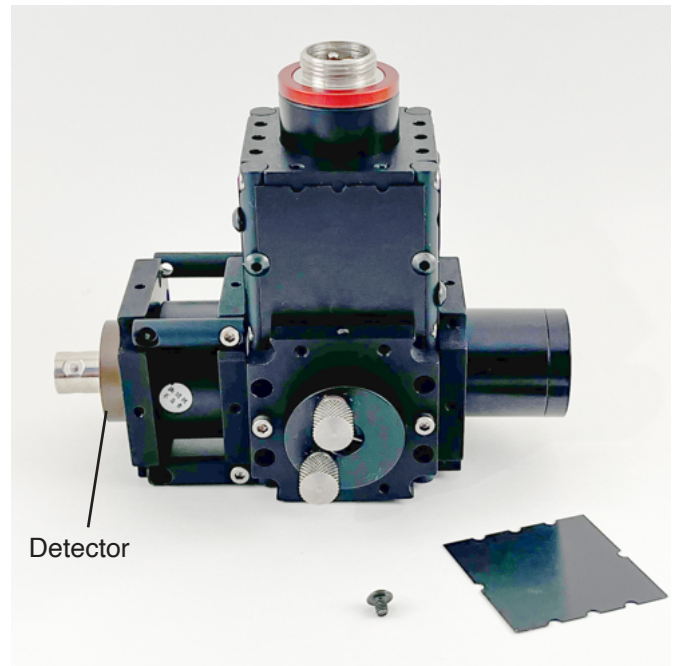
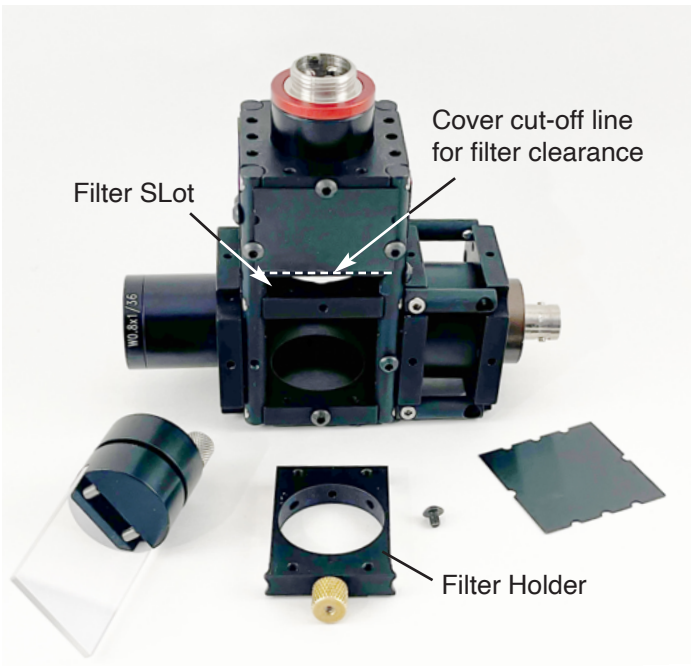

Left, further assembly with beamsplitter, and filter holder still out, Right, below, fully assembled with one cover plate off.

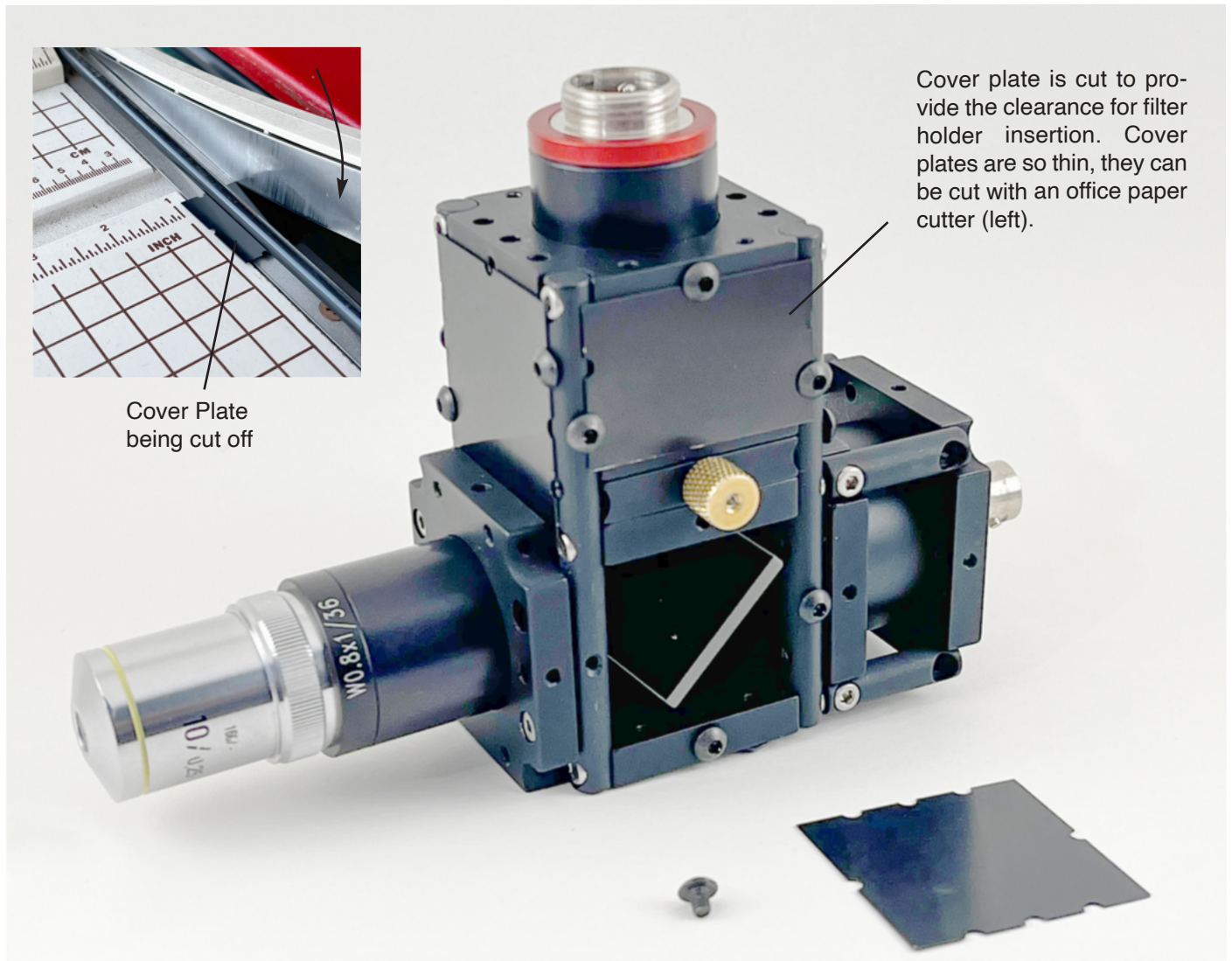

Fully assembled setup with a 10X microscope objective ready to use. Cover plate remains off to show the beamsplitter.

Optoform 40 Opto-mechanical Componets

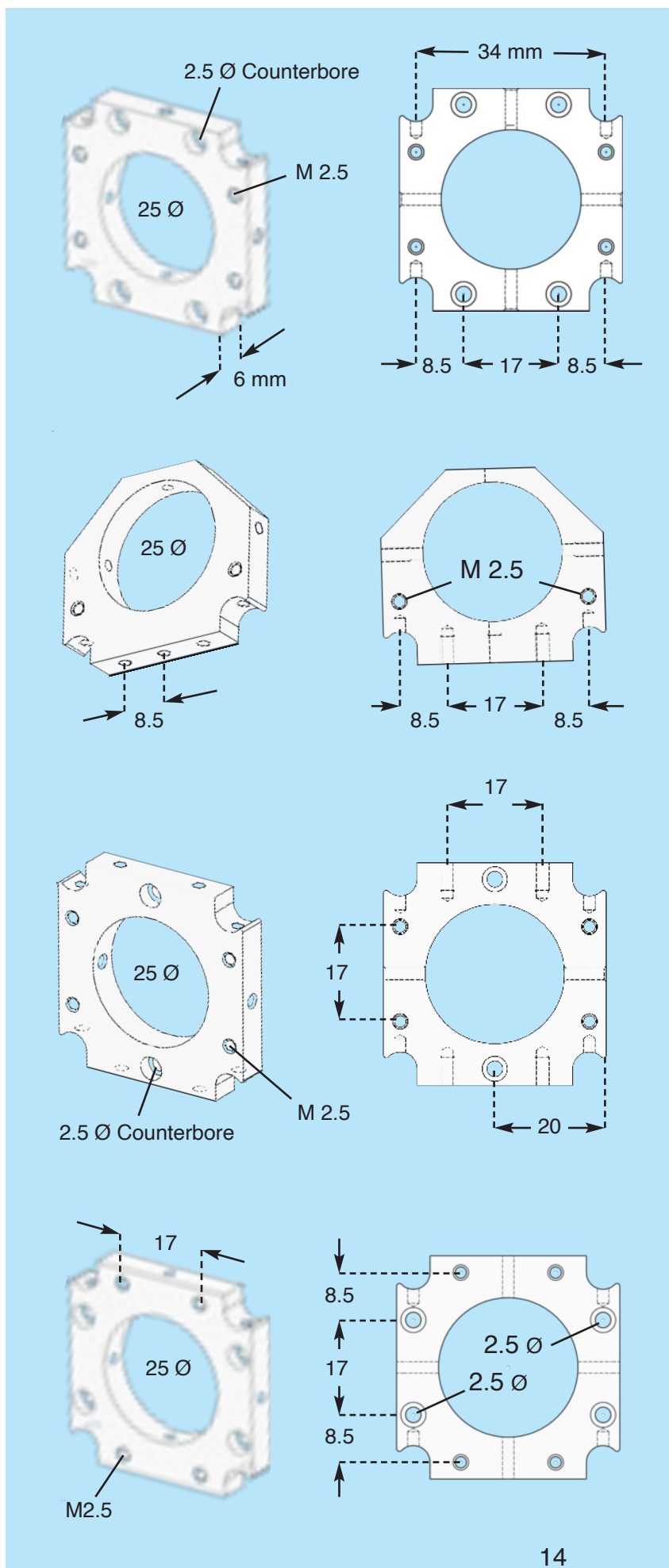

40-100 Standard Mount 25

Basic building block for optical setups with 25 mm mounting bore to secure 25 mm mounted optics, and accessories. It has four 2.5 \O mm counter-bores and four M2.5 tapped bores. May be mounted on support rods via M2.5 screws. Mounting plates may be secured together face to face, or at right angles via 40-104.

40-100S Standard Mount 30

Identical to 40-100 but with 30 mm clearance aperture.

40-102 Compact Mount 25

Compact mount intended to secure on two rods to support 25 mm mounted optics, and accessories. There are two M2.5 tapped bores at their base, 17 mm apart, that allows mounting to other mounts at right angles via M2.5 screws.

40-104 Right Angle Mount 25

Allows direct mating of two adjacent mounts at right angles via two M2.5 mounting screws. It takes two pairs of 40-104 and 40-100 to construct a cube. A better alternative would be to utilize four rods.

40-104S Right Angle Mount 30

Identical to 40-104 but with 30 mm clearance aperture, and no counterbore.

40-106 Mating Plate 25

Identical to 40-100 but with opposite counter-bores, and tapped bore placement to allow securing the two mounts together. By utilizing 40-100, and 40-106 on mating ends of subassemblies, they can be attached, or detached while maintaining their own function, such as a Halogen lamp assembly, or beamsplitter housing.

40-106S Mating Plate 30

Identical to 40-106 but with 30 mm clearance aperture.

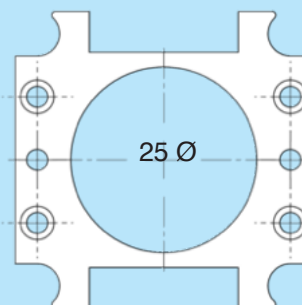
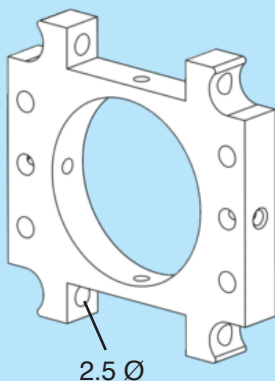
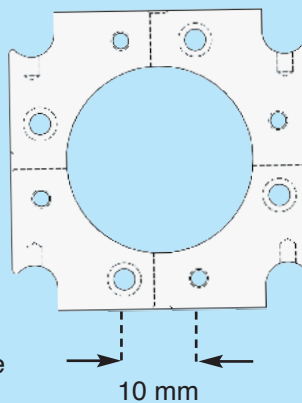
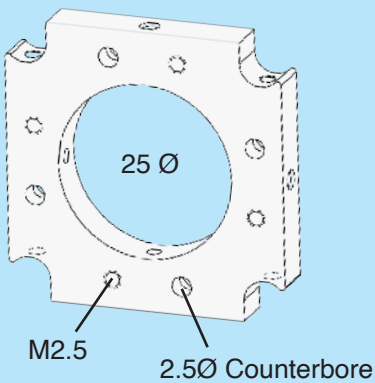
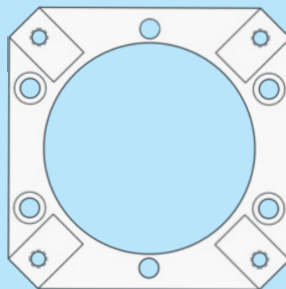
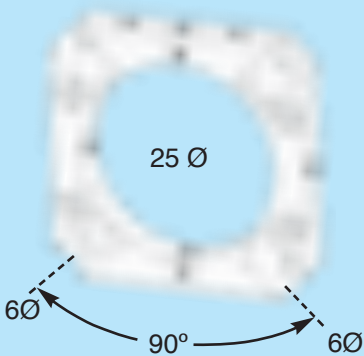
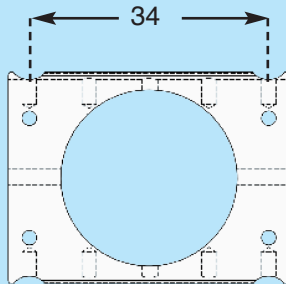
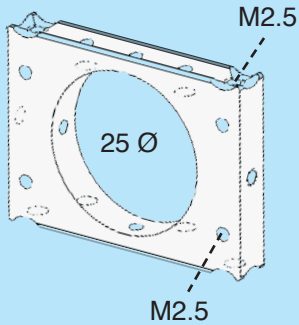
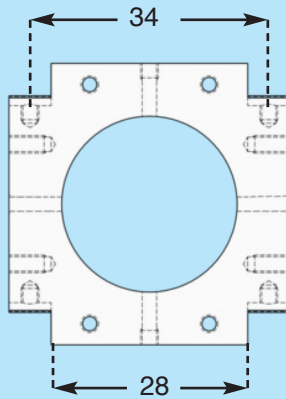
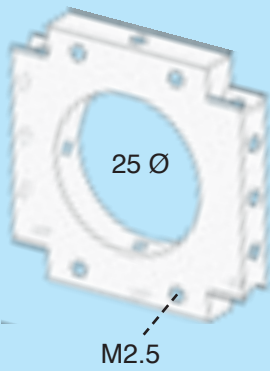

40-108 Intermediate Mount 25

It creates optical paths in between two rods, without causing mismatch to an assembly. For example, by adding two 006-23 rods to 40-108, its length will match with rods 006-74. The formula to obtain correct rod lengths is:

$$L1 = (L2 - 28 \text{ mm}) / 2$$

Where L1 = Shorter rod, L2 = Longer rod

40-110 Sliding Mount 25

Can be inserted in between two rods to shift the position of optical axis along the rods, i.e., where the position of eyepieces in a binocular application needs distance adjustment. It may also be utilized to interconnect two or three rods at right angles.

40-118 Standard Mount 25

Accepts 6 mm rods in diagonal direction and mates to 40-100, and 40-106 to build three dimensional structures. Accepts Micromax 25 tubes, and other mounted optics.

40-130 Microbench Adapter 25

Has matching bore pattern to mount against Microbench cube 25/30, and mount 06-1041, to have full integration with Microbench mounts, and accessories.

40-134 Side Mount 25

Accepts M2.5 screws from inside out to mount along the rods with M2.5 bore pattern. It will secure optics along the 6 mm rods.

40-136 Side Mount 25C

Identical to 40-134 but in the compact form of 40-102 to mount along the rods with M2.5 bore pattern.

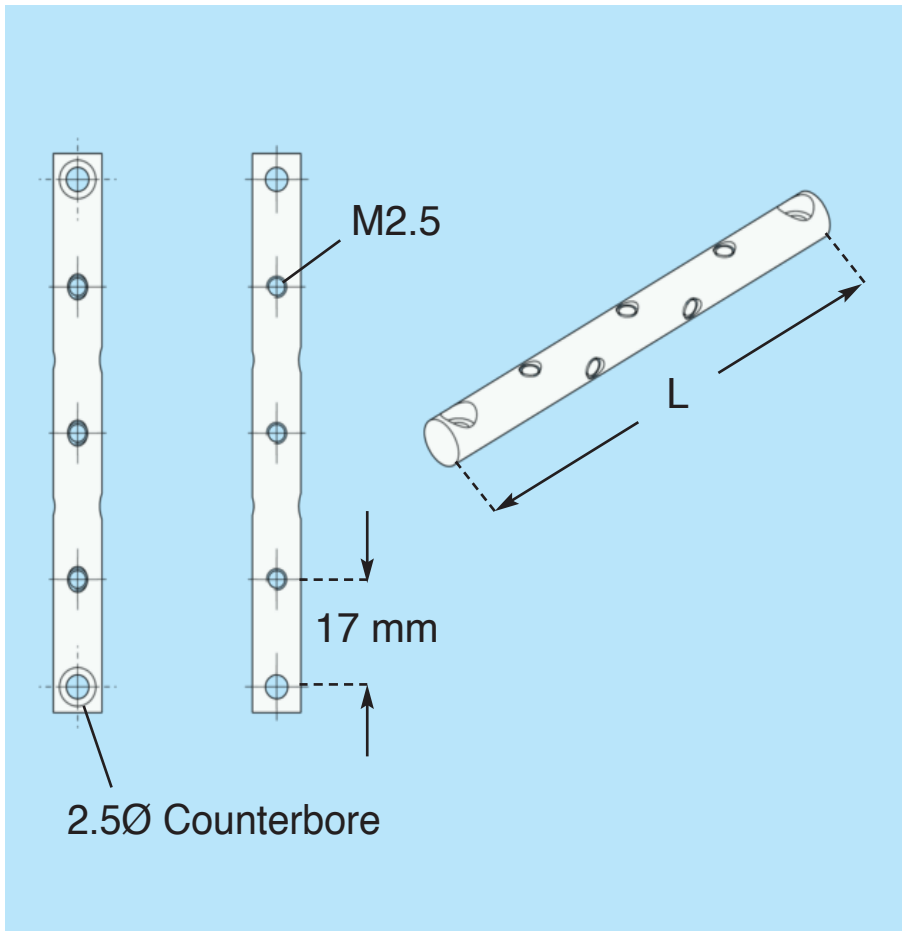

Support Rods		
Aluminium Alloy	Stainless S	
006-12, L= 12 mm	Special Order	
006-20, L= 20 mm		
006-23, L= 23 mm		
006-40, L= 40 mm		
006-50, L= 50 mm		
006-57, L= 57 mm		
006-65, L= 65 mm		
006-74, L= 74 mm		006-74S
006-80, L = 80 mm		006-80S
006-108, L= 108 mm		006-108S
006-128, L= 128 mm	006-128S	
006-142, L= 142 mm	006-142S	

Mounting Hardware

00-116	M2.5x10 Thumb screws, pack of 5	For securing accessories on M2.5 threaded bores
00-120	M2.5x10 Low profile, 25 pcs	For securing two mounts face to face
00-125	M2.5x6 Socket screws, 100 pcs	Standard rod securing screw
00-126	M2.5x3 Set screws, pack of 100	Optics securing screws, L = 3 mm
00-128	M2.5x6 Set screws, pack of 100	Optics securing screws, L = 6 mm
00-129	M2.5x4 low profile, 25 pcs	For sheet covering around Optoform 40 assemblies
00-222	M2.5 Nut, set of 10	For securing accessories along M2.5 set screws
00-248	Ball driver set 1.27, 1.5, 2 mm	For constructing Optoform 40, and 74 assemblies
006-40F	6 mm rod, L = 40 mm, set of 12	Special 6 mm rods with M2.5 threaded ends, with detent

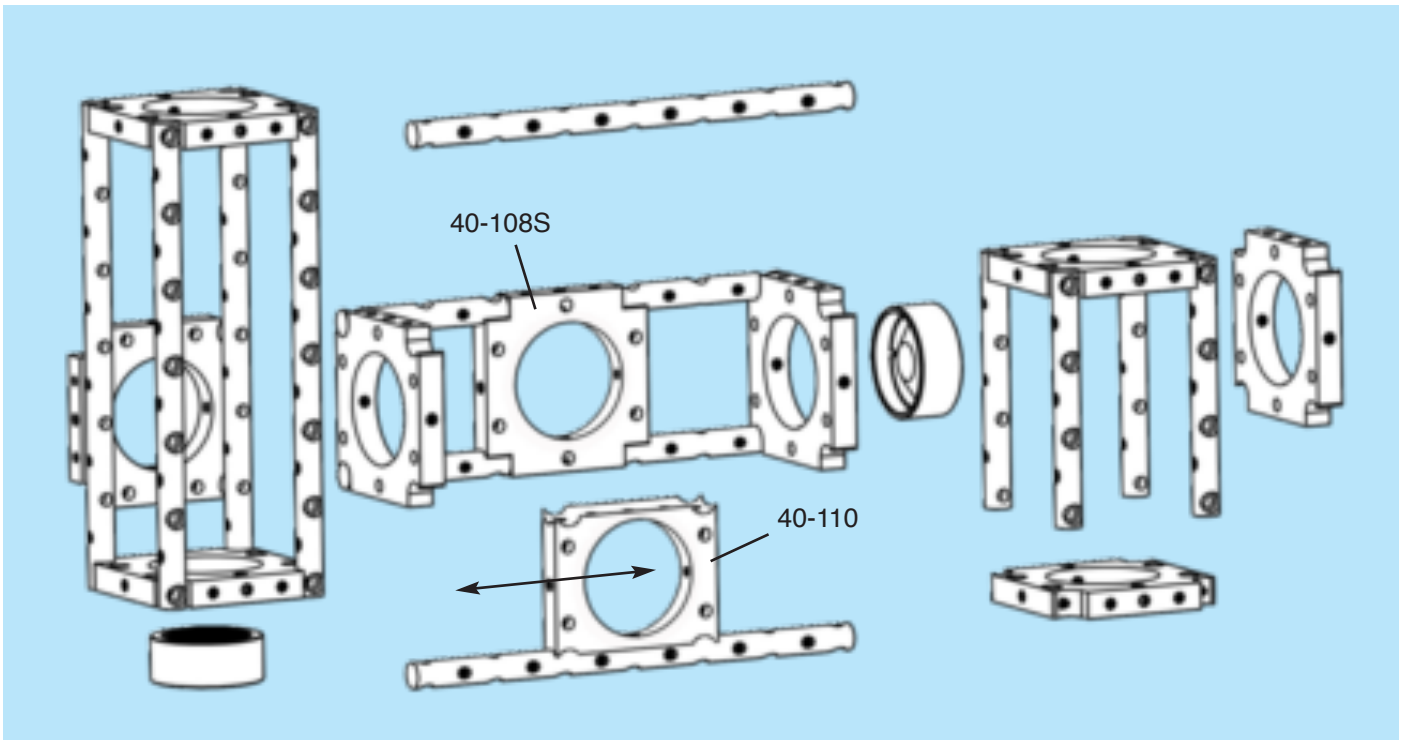

What would happen if you turn support rods to corner connectors? Unlimited mounting possibilities

Optoform is the most innovative prototyping tool for product development. It is an iconic trait to create your new ideas, with design elegance, and value engineering. It provides both optical assembly, and housing, all self holding, and all self supporting. All Optoform components are made of Alluminum Alloy 60-61, anodized in dull black for durable low reflection finish.

A reversible concept

Optoform rods could be either bolted onto the mounts or the mounts could be secured onto the rods (using 40-134). The end result always grows with your imagination, and knowledge of the system.

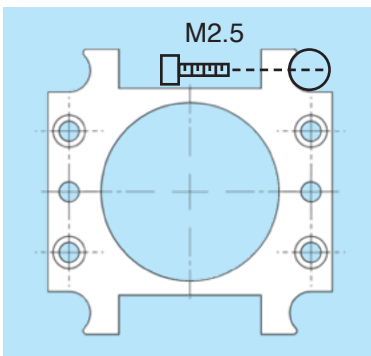

40-134

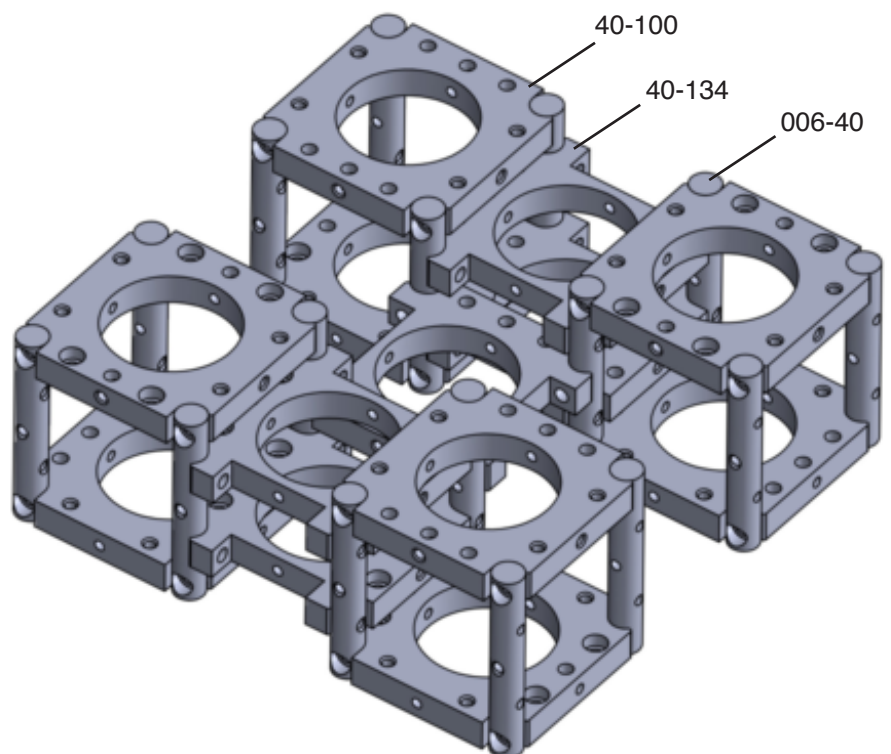
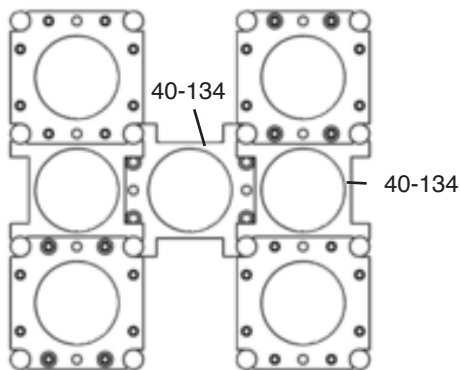

Cover Plates

Sheet covering in Optoform may be easily cut to size by household shears. There are also nibbling tools available to provide clearance notches for mounting screws.

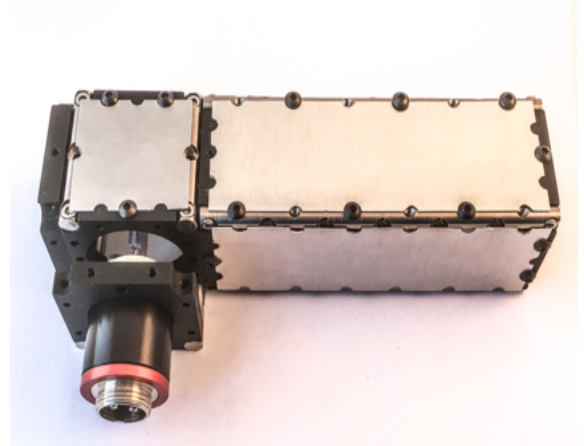
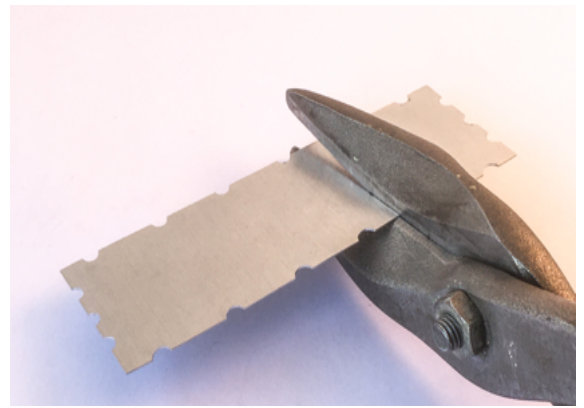
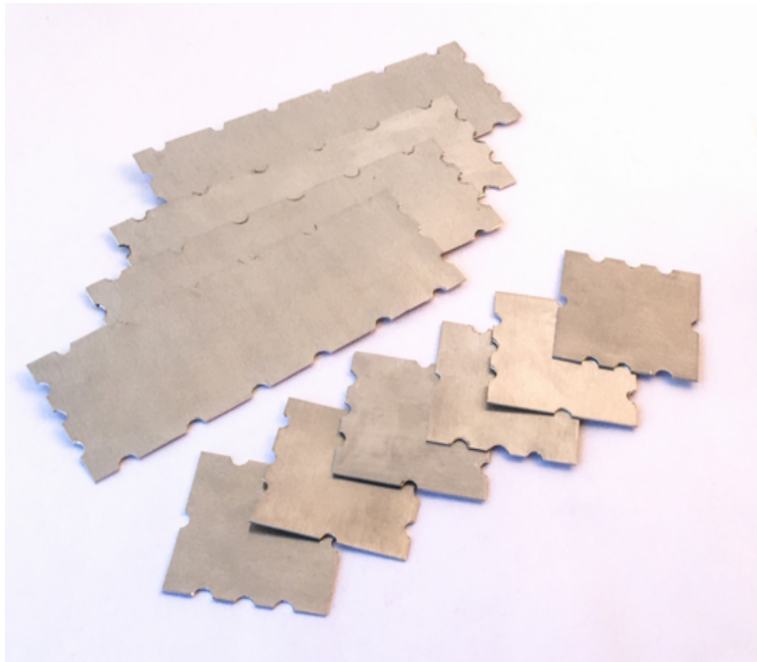

00-500	14 X 34 mm, 0.3 mm Thickness	For covering 20 X 40 space frames
00-502	34 X 34 mm, 0.3 mm Thickness	For covering cube 40 X 40 faces
00-504	34 X 51 mm, 0.3 mm Thickness	For covering 40 X 57 space frames
00-506	34 X 68 mm, 0.3 mm Thickness	For covering 40 X 74 space frames
00-508	34 X 102 mm, 0.3 mm Thickness	For covering 40 X 108 space frames
00-510	34 X 136 mm, 0.3 mm Thickness	For covering 40 X 142 space frames
00-512	68 X 68 mm, 0.3 mm Thickness	For covering cube 74 X 74 space frames
00-514	68 X 102 mm, 0.3 mm Thickness	For covering 74 X 108 space frames
00-516	68 X 136 mm, 0.4 mm Thickness	For covering 74 X 142 space frames
00-518	68 X 120 mm, 0.4 mm Thick, Set of 2	Special 74 X 126 binocular head's top cover
00-520	68 X 102 mm, 0.4 mm Thickness	For covering 74 X 80 linear bearing assembly

Cover plates are cut at the center-line of M2.5 screw bore pattern around their periphery. This allows cover plates to lay side by side around the space constructed by mounting plates, and support rods. In optoelectronics projects, cover plates may be drilled, and nibbled to secure electronics connectors, and switches. The standard color for cover plates is anodized light gray. Unanodized version of cover plates are also available to take any desired color.

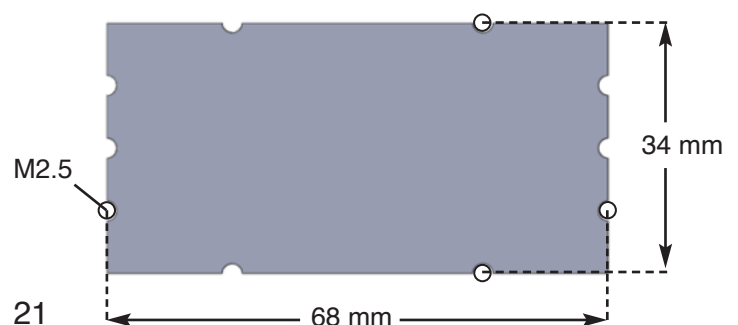

From basics all the way to highly advanced setups: Building a Telescope

You'll be able to construct these examples such as this simple telescope with parts from the basic **Basic Optoform kit 40-706**. This kit contains some Micromax parts such as an eyepiece holder (25-354), and an objective holder (25-198). The objective holder secures 25 mm mounted lenses such as $f = 150\text{mm}$ (20-022) from the **Basic Optics Kit 20-914**. All our 25 mm lens cells can screw directly to Micromax tubing (25-128 or -130) but the 150 mm plano convex lens faces the wrong direction. This is how the lens cell adapter 25-198 becomes useful. Other tubes could also mate together via retaining rings 25-306, such as eyepiece holder 25-354, and tube 25-128 as shown below.

We'll use two mounting plates 40-100, and 40-106 to secure the eyepiece at one end, while securing the objective at the other. Optoform 40 assemblies are built like stackable cages, to allow their reconfiguration in the most modular way. The focusing is performed within the mounts via Micromax tubing.

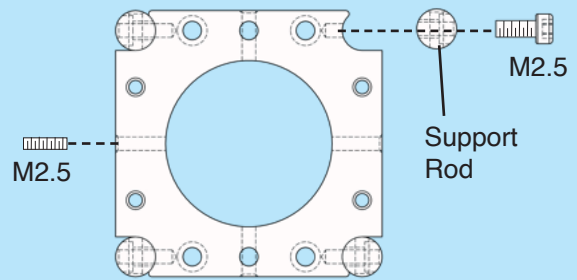
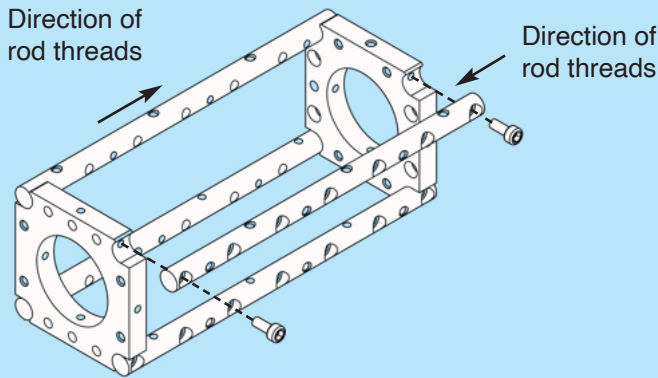
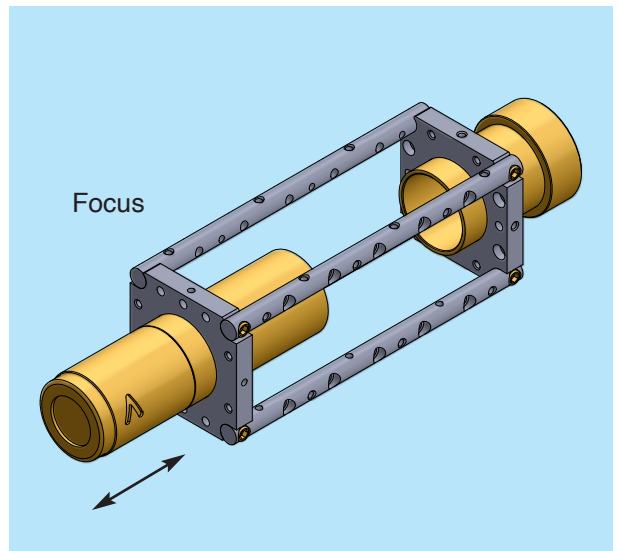

Cross section of mount 40-100

Above, what not to do in assembling odd sized rod legths..

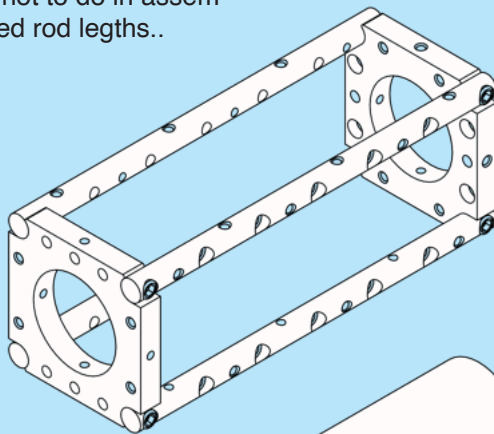

if rods are mounted in random direction, the likeliness of finding covering would decrease.

(10X Eyepiece)

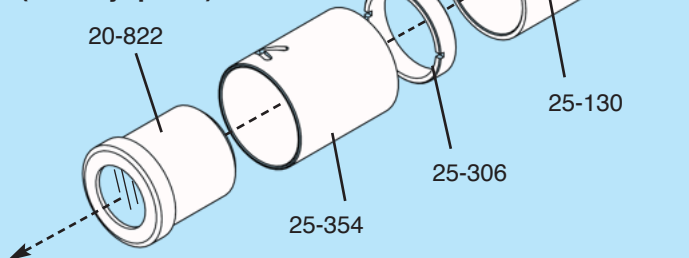

(Objective)

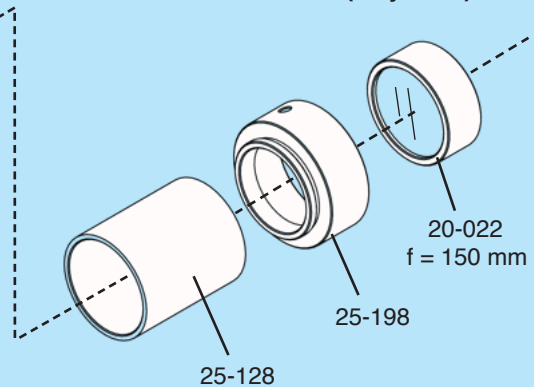

Telescope with right angle viewing

The advantage of Optoform's modularity can now be examined when building this simple telescope with right angle viewing. Basically, we'll take out the eyepiece of the first telescope we built, and build a cube around it and a mirror holder to bend the light 90 degrees.

Optoform 40 is so compact that we need to extend it on one end to secure the existing mirror holder 50-352, and be able to center the mirror on the main optical axis.

There are several ways to accomplish this. We'll try the quickest method (Shown below), and that is to stack two mounts together: 40-100S, and 40-106. The 40-100S provides the tilt clearance for mirror mount 50-352 while the stationary end is being held by 40-106.

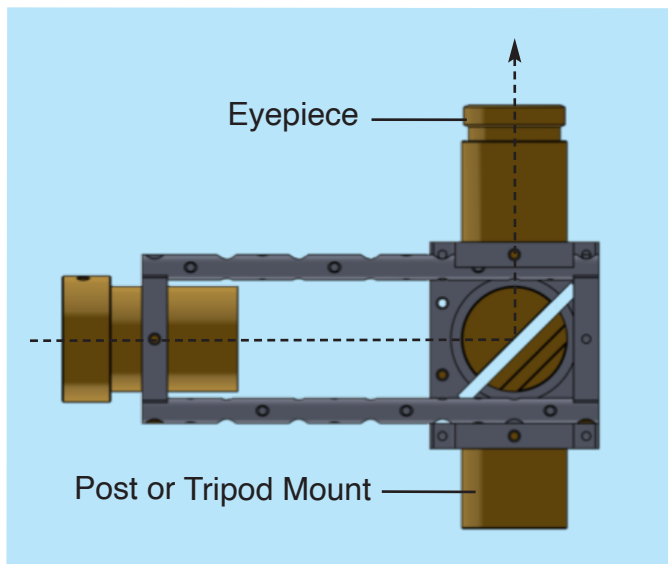

This telescope gives an upright image orientation, and much better user comfort around the lab.

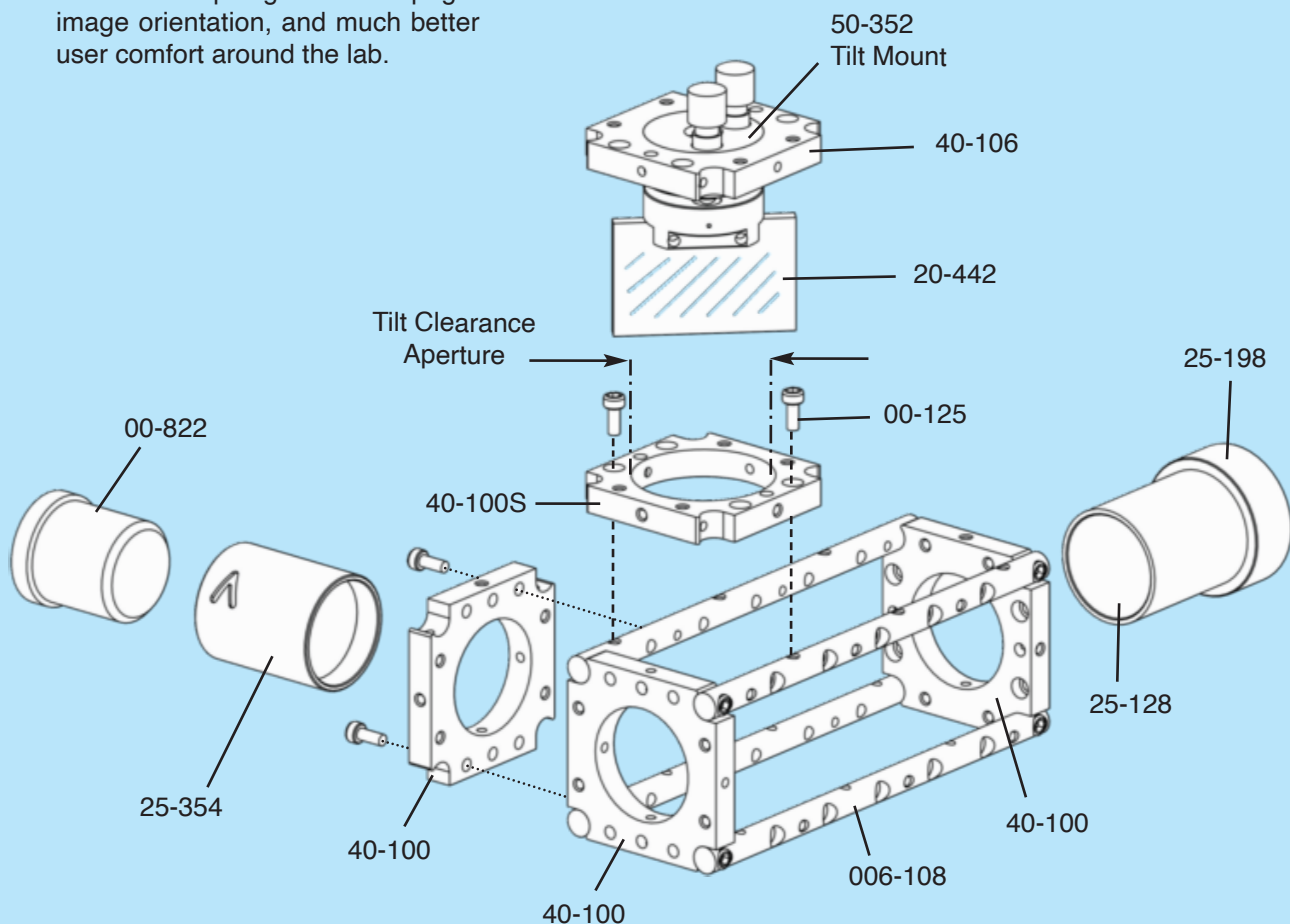

The back end of tiltable mirror mount 50-352 is held by 40-100 while its front end is given space for its tilt adjustment inside the 30 mm clearance aperture of 40-100S.

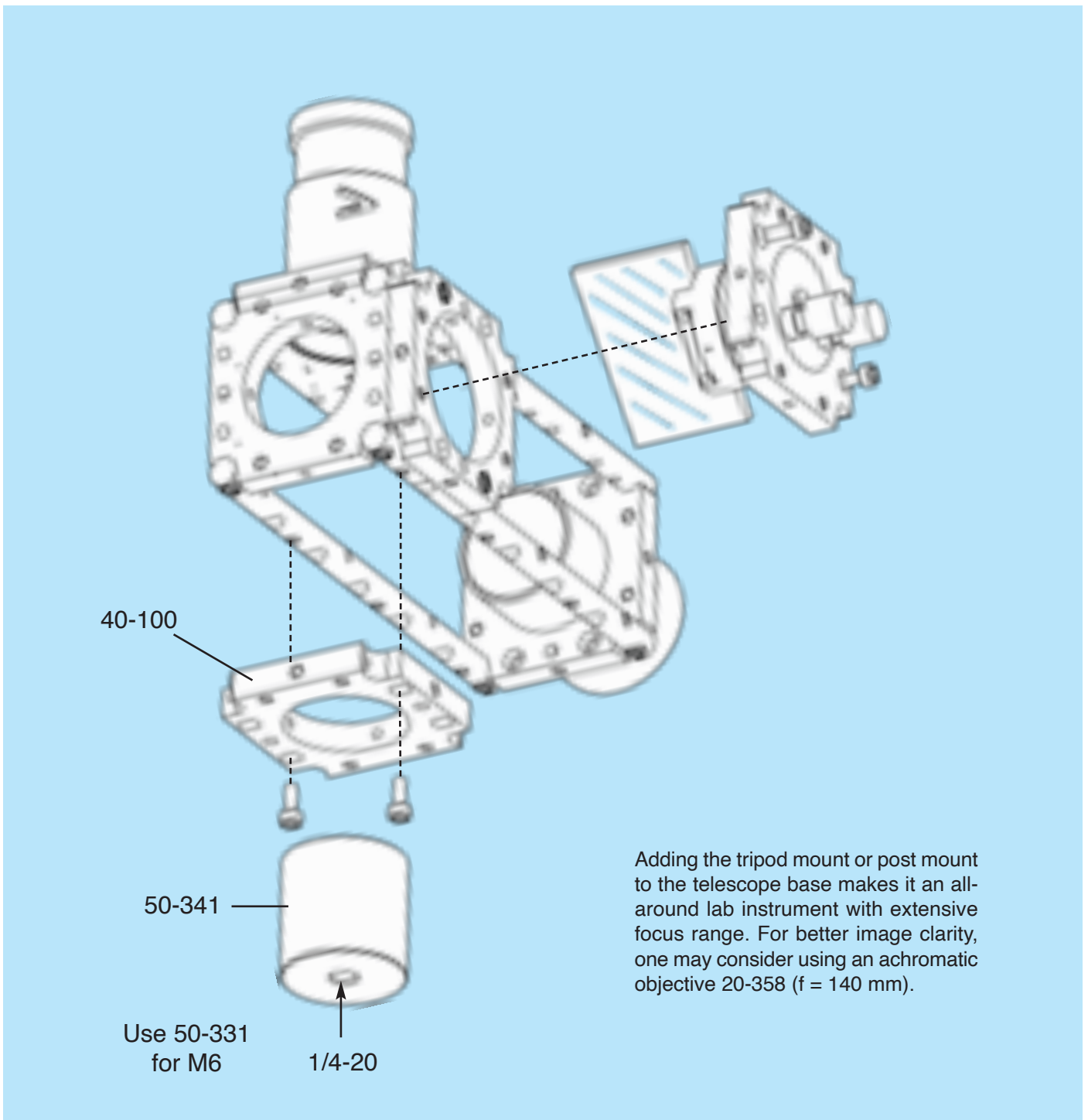
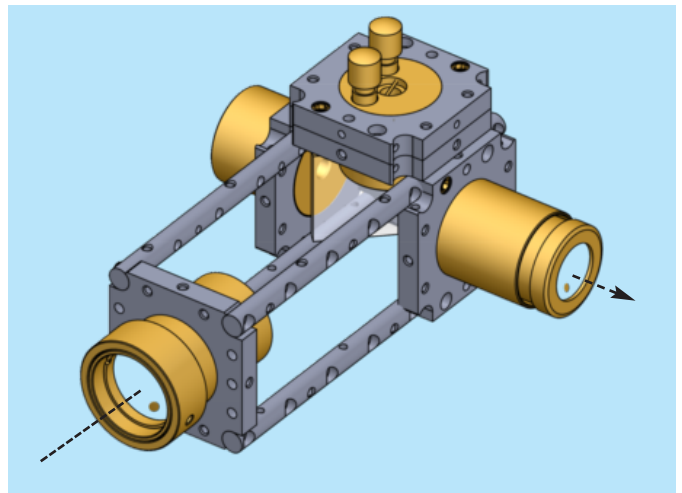
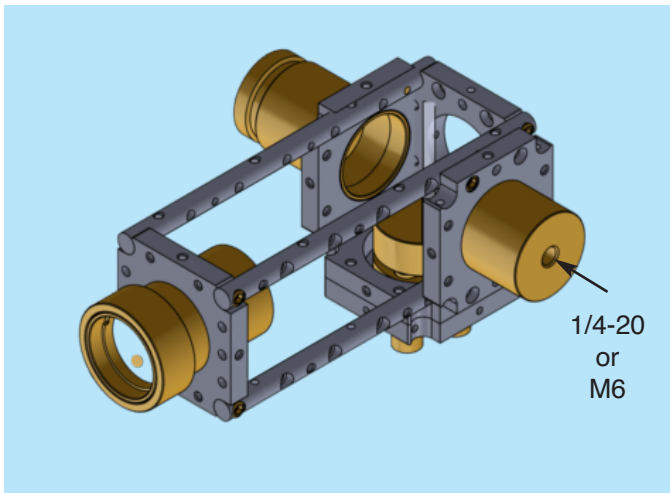

Building a Halogen Lamp Housing

Before building microscopes, we'd better start with a lamp housing. Halogen is the most widely used light source other than LEDs.

The collimating optics 20-250, and concave mirror 20-480 are oriented in their lens cells such that Micromax extension tubes may be added to position them closer to the lamp (below). The Halogen beam is collimated, then focused to the sample by an additional lens (An optional double convex lens 20-108, $f = 16 \text{ mm}$ is recommended).

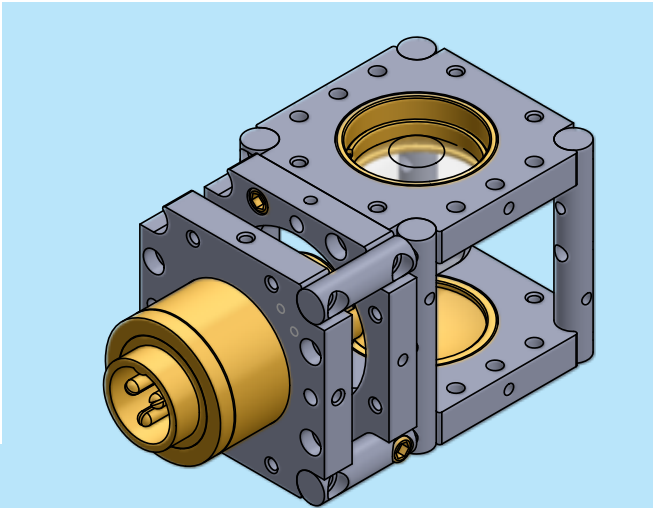

Halogen Lamp Assembly

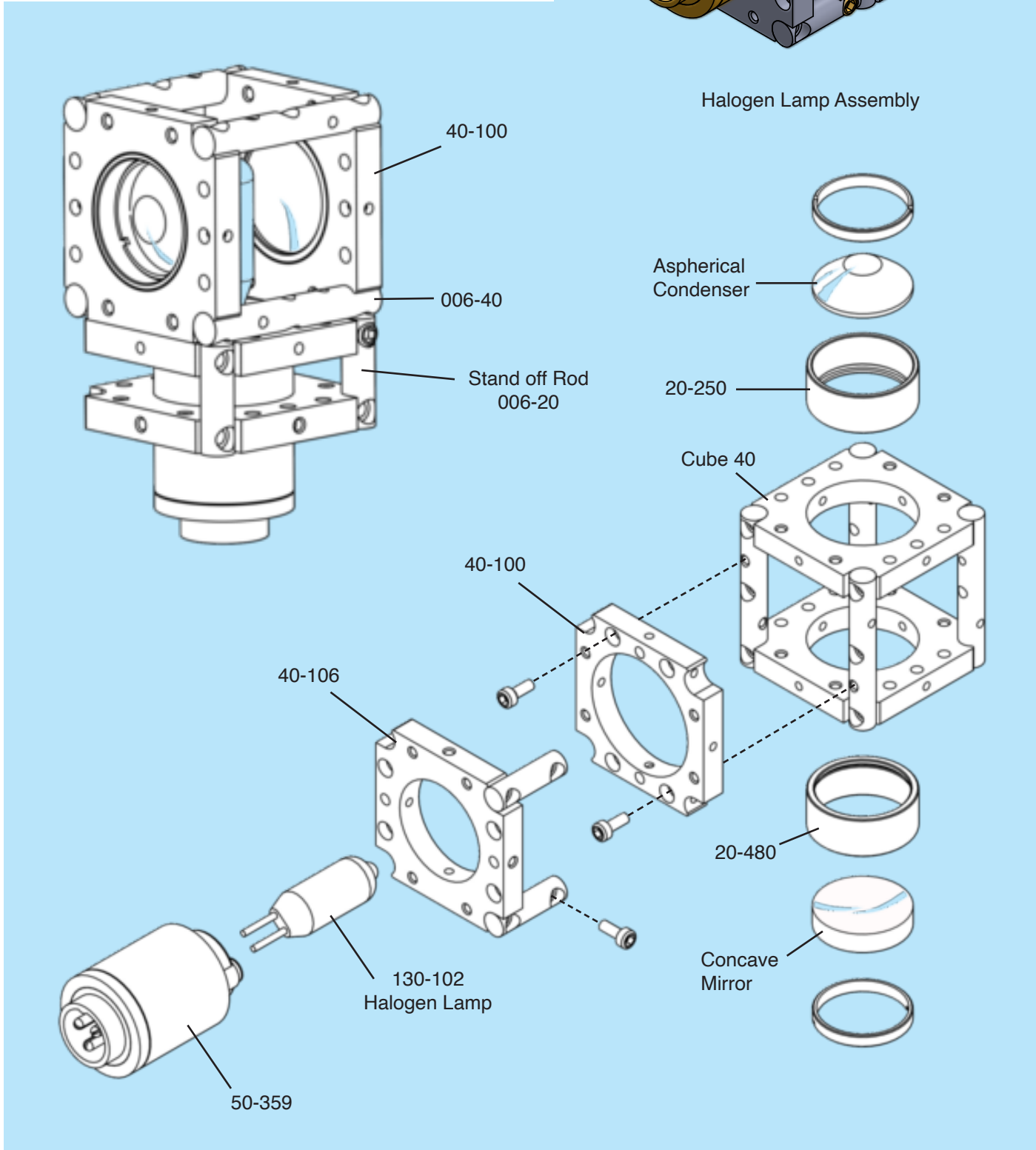

Building a Biological Microscope

Now that we have a proper light source, let's construct the microscope body. For standard microscope objectives, we need a 160 mm long tube. This is constructed by adding Micromax tubes 25-128, 25-130, and the eyepiece holder 25-354. The four tubes are joined together by three extended retaining rings 25-306. The objective mounting ring is assembled by adding 50-331, and 25-332 to the bottom of the tube. Sample holder spring plate 00-852 secures standard microscope slides.

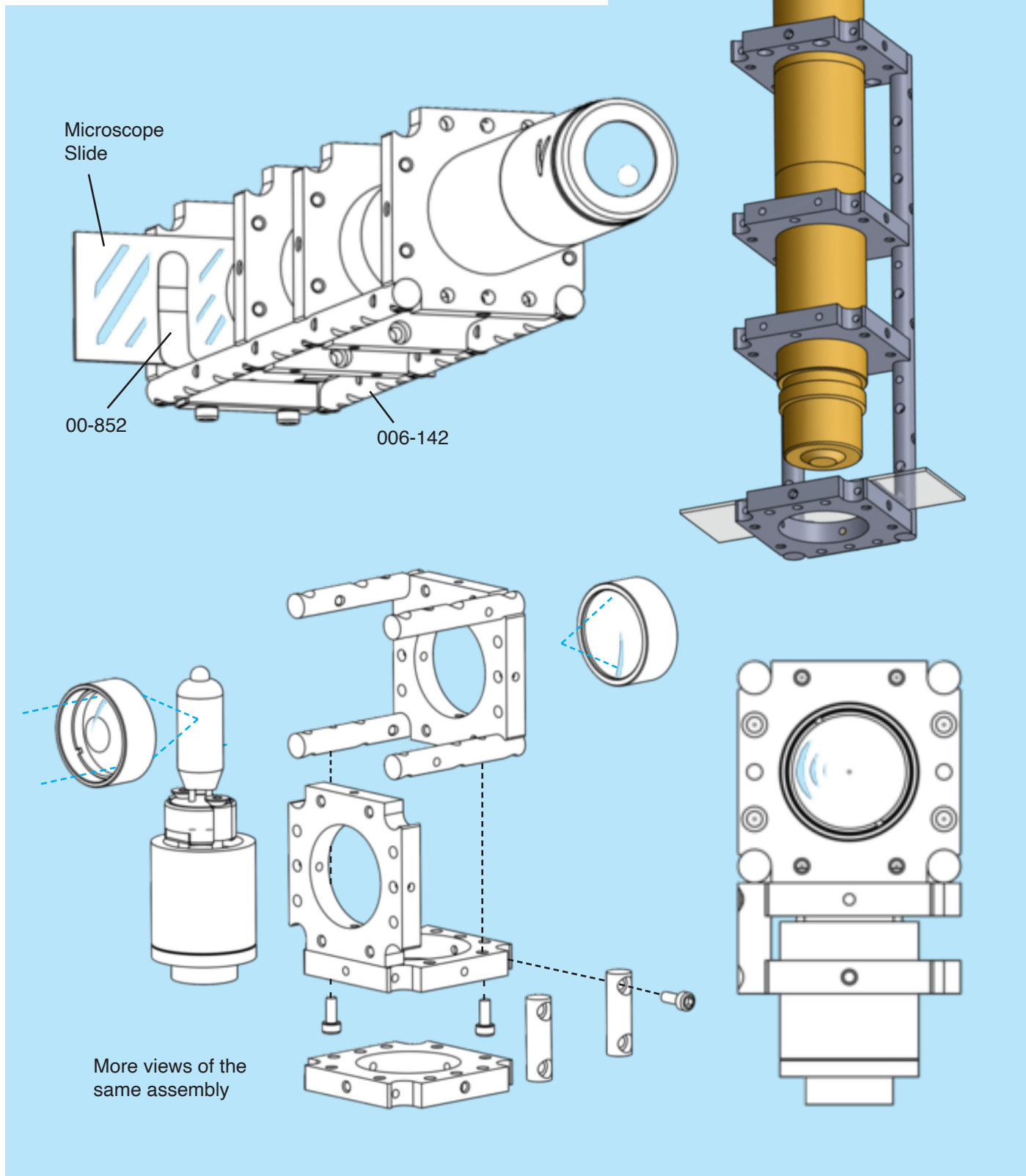

Building a Tilt Platform

Designing a platform for optical instruments in the lab has been long forgotten because so far, there has been nothing available for it. This would be like owning a camera without a tripod! Instruments need platforms, and Optoform wishes to offer it to optical labs. Platform offers user interface, and ergonomics that you can't achieve by using post mounts that can only shoot up vertically from optical tables like a rocket.

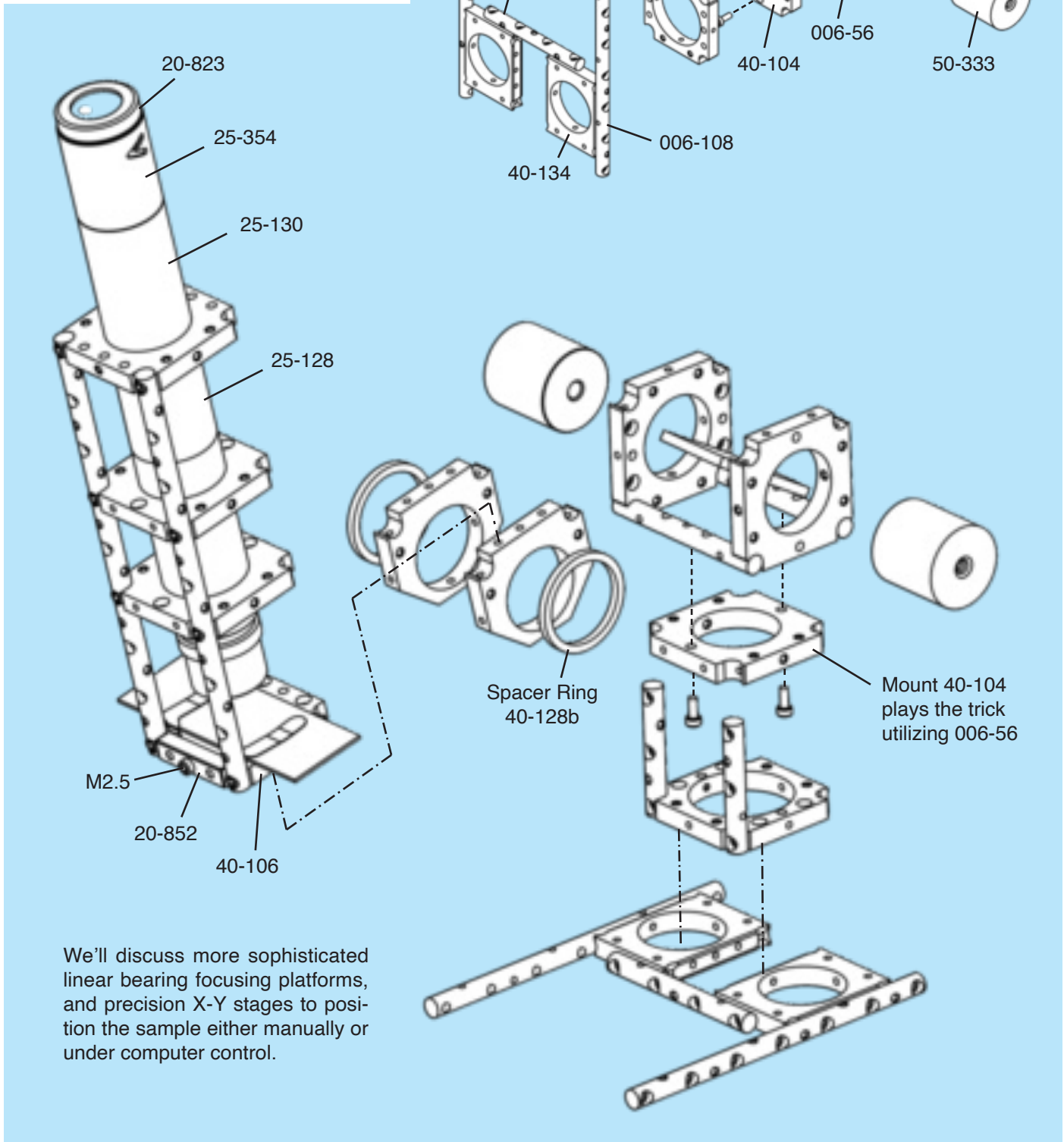

We'll discuss more sophisticated linear bearing focusing platforms, and precision X-Y stages to position the sample either manually or under computer control.

Final Assembly

This is a classical instrument built with modern components. The first improvement that was offered to microscopes was a tiltable platform so the user could sit with his/her knees under a desk, and stare through the microscope eyepiece without neck strain.

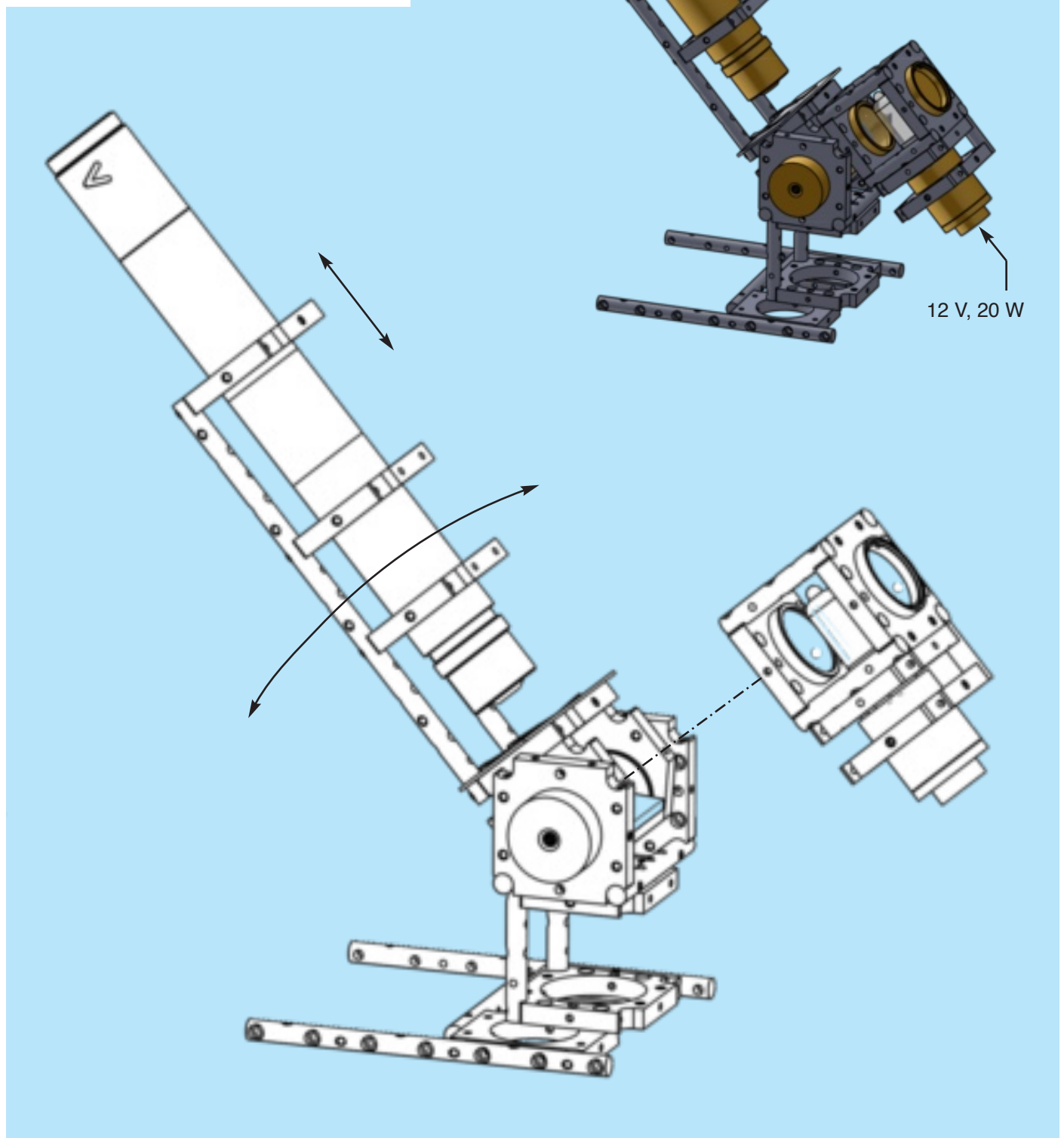

The Autocollimator

Although already discussed in the introduction, more details of this design will be illustrated in its Solidworks modeling. Proper illumination solution for this instrument is to project the lamp filament on the objective lens. It ensures corner to corner illumination for the reticule while it is viewed through the eyepiece. There are two devices that would need to center its filament with the optical axis, and the other is 50-352 which uses a combination stack of 40-100, and 40-106S to position the beamsplitter 20-450 along the optical path.

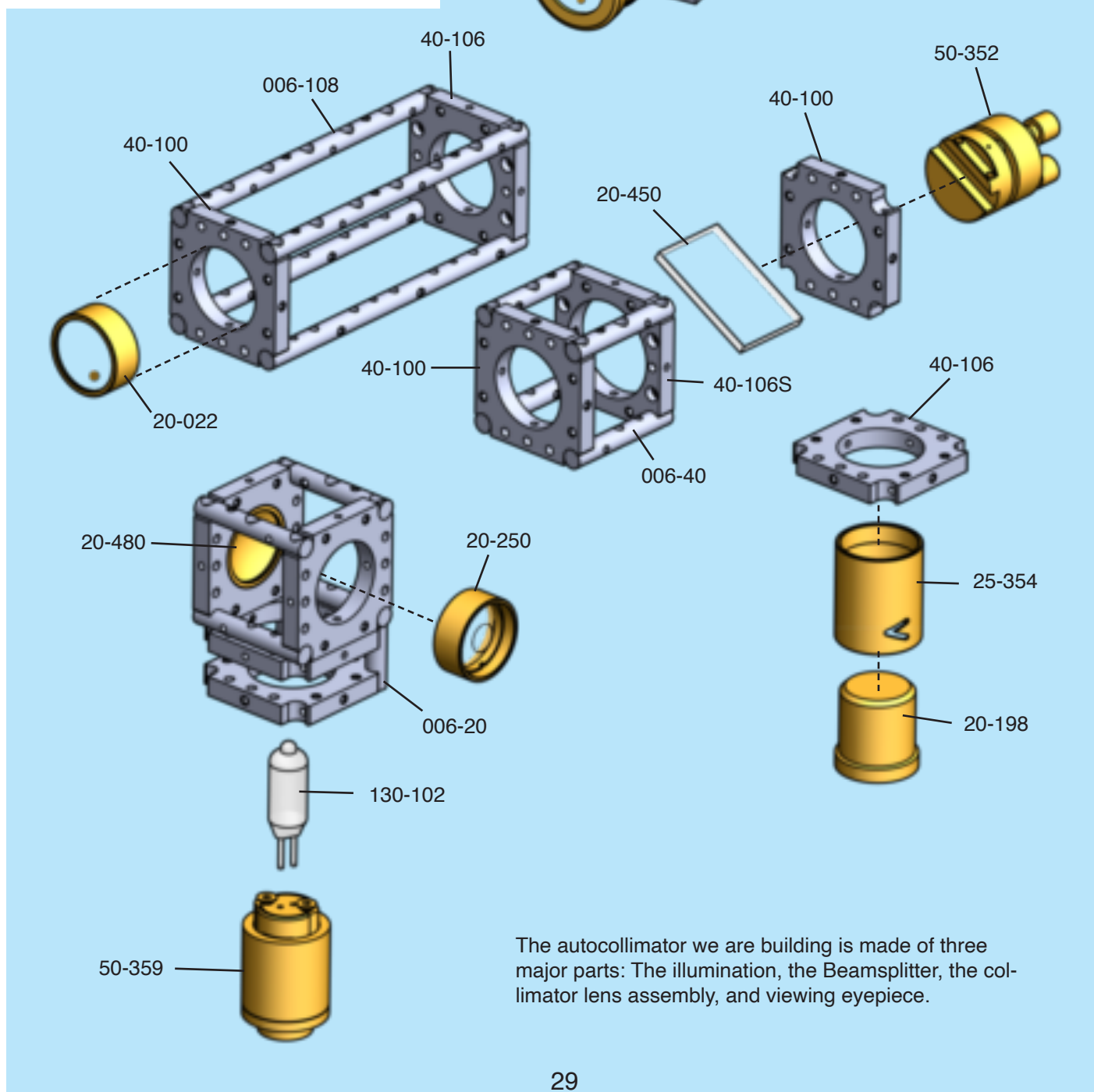
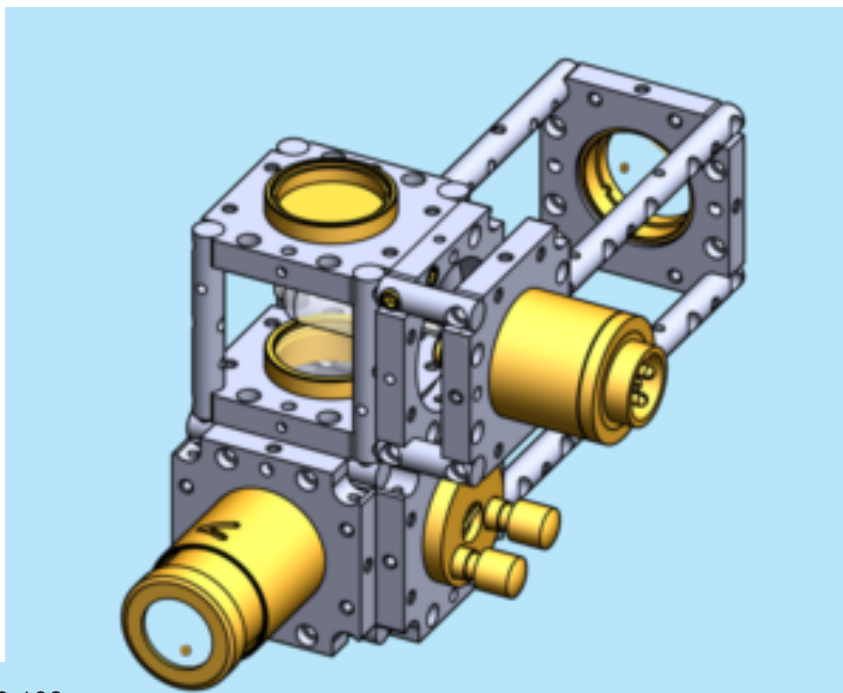

The autocollimator we are building is made of three major parts: The illumination, the Beamsplitter, the collimator lens assembly, and viewing eyepiece.

Reconfigure

Now that we have built all the subassemblies, we could arrange them in many ways to construct the autocollimator. For example, the viewing eyepiece could be positioned horizontally, or at 90 degrees. The lamp cable could be oriented to extend from the back or to be attached from the side. All these re-arrangements can be accomplished by removing 6 connecting screws.

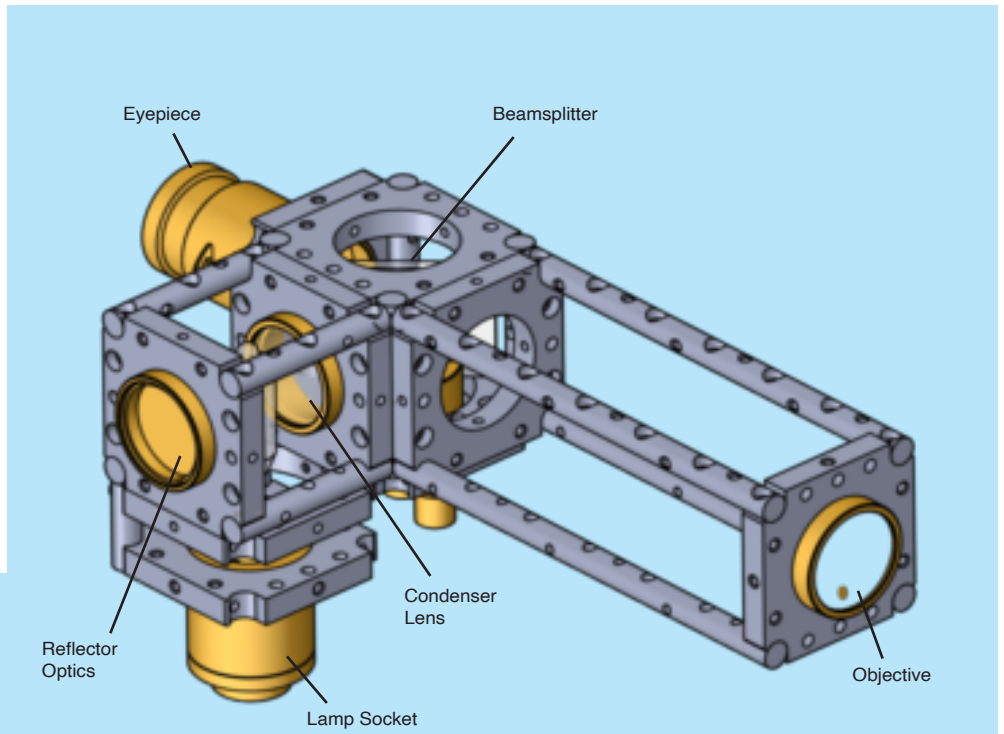

Viewing Position

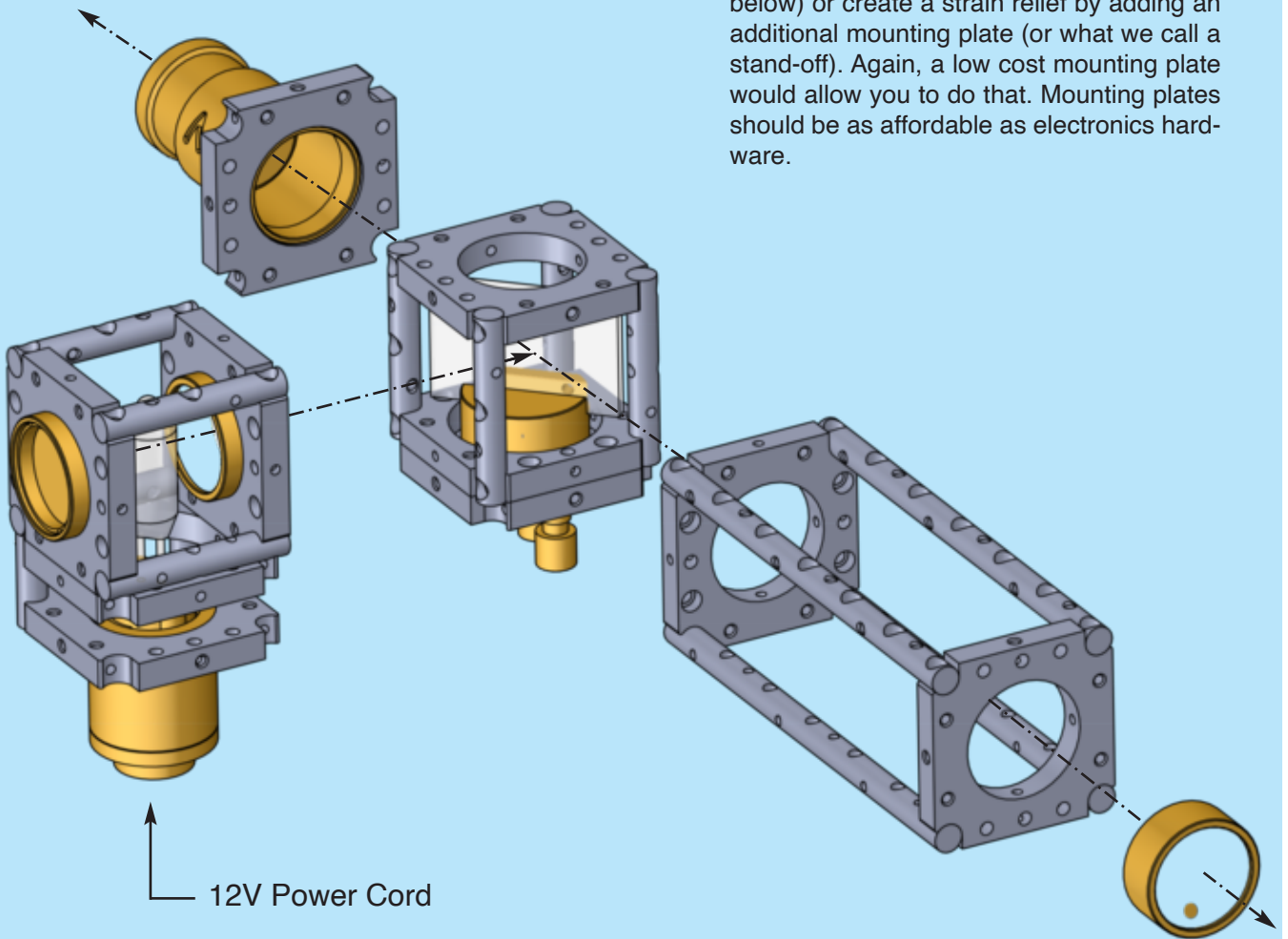

In optical instruments, the best way to connect power is to do it vertically (as shown below) or create a strain relief by adding an additional mounting plate (or what we call a stand-off). Again, a low cost mounting plate would allow you to do that. Mounting plates should be as affordable as electronics hardware.

Building a Spectroscope

To build a spectroscope, we first need to construct a Swivel mount. The trick in here would be to utilize a pair of support rods 00-56, mounted to a pair of 40-106 mounts as shown below. Then a pair of 40-102 is mounted on both sides of mount 40-100. By inserting two cylindrical platforms 50-341 or 50-333, and two spacers 00-128b, a swivel mount can be constructed as shown below. This assembly may be supported by inch or metric post mount.

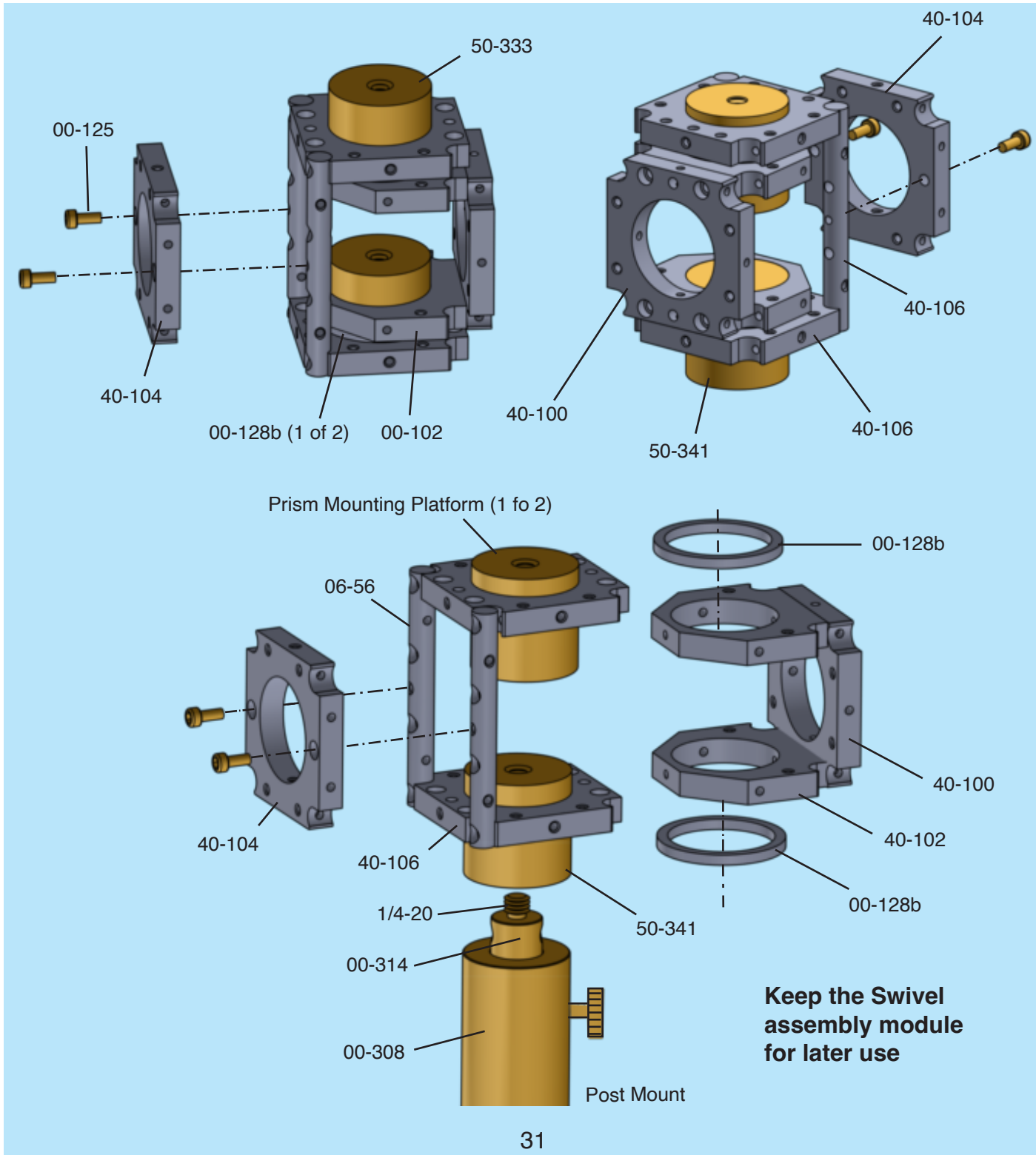
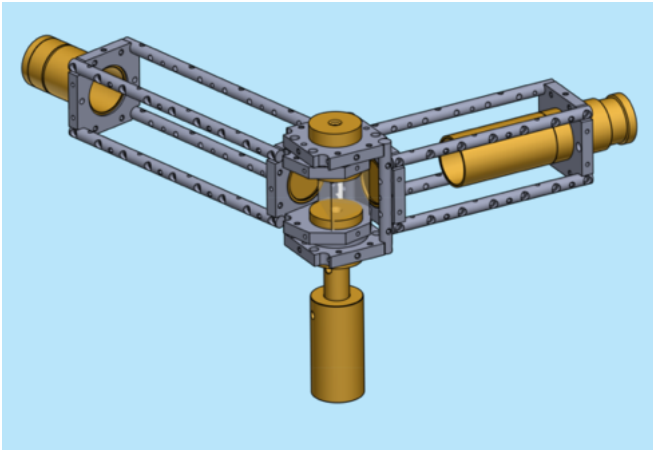

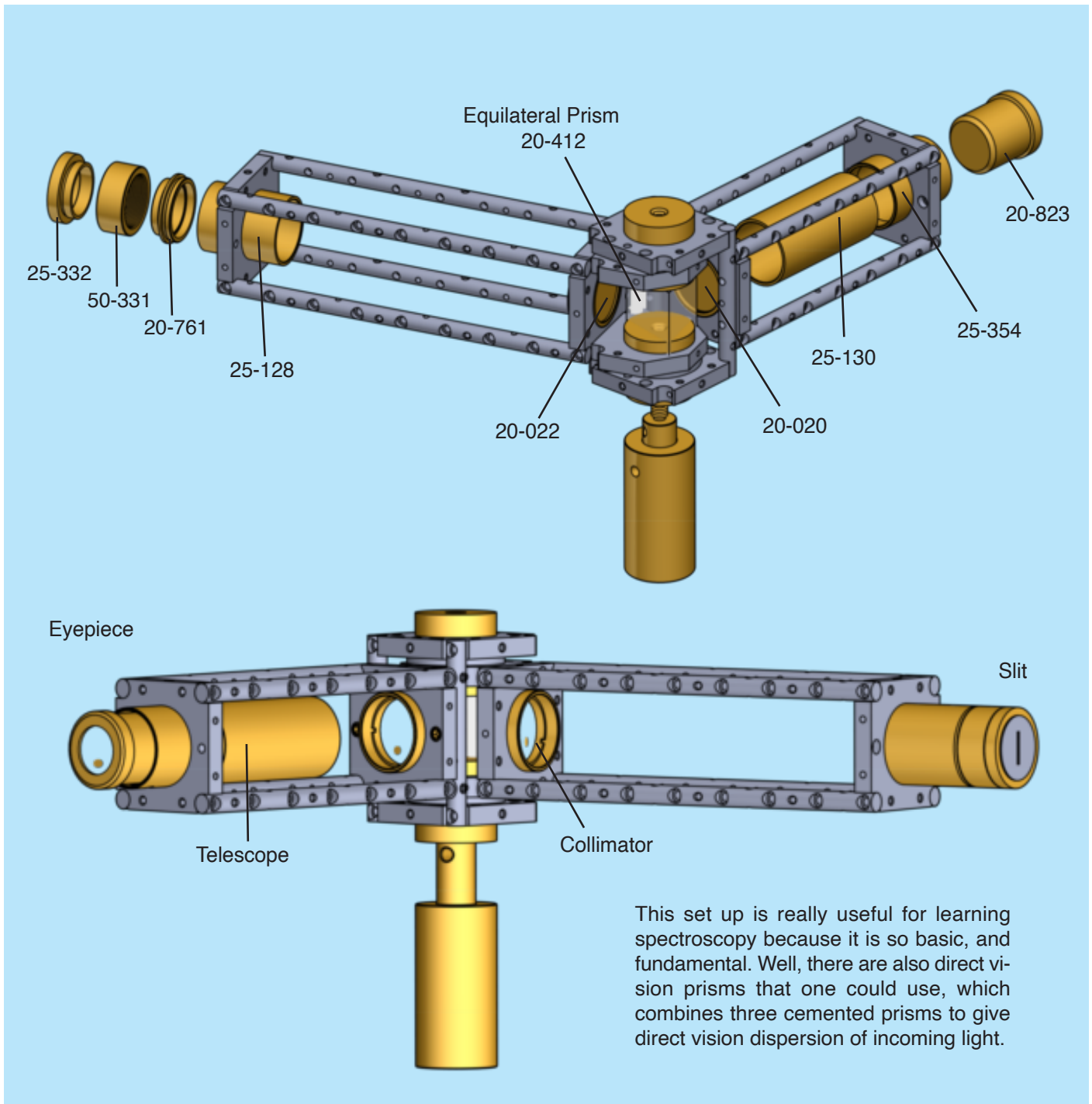

This set up is really useful for learning spectroscopy because it is so basic, and fundamental. Well, there are also direct vision prisms that one could use, which combines three cemented prisms to give direct vision dispersion of incoming light.

Building a Sample Holder

This is the most undermined task in most labs. Building a sample holder involves a test tube being held on a reliable platform, and illuminated from the back by a relatively constant light source with a reasonably flat spectrum output curve. We could utilize the Halogen lamp we built for previous experiments to get us going on this. Test tube holder can be constructed with two mounting plates 40-102/136, and two rods; One could mount on the edge of the rod, and the other on the middle (R).

The most difficult task is to get the light source, and the test tube line up with spectroscope's input slit. In conclusion, this setup shows the possibility of performing tilts and rotation with standard optoform mounts. It may be applied to many other applications such as a tiltable viewing head for microscopy.

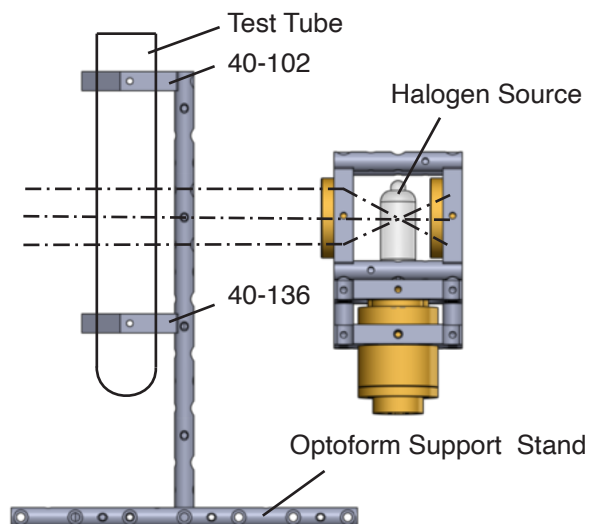

Final Assembly

The main objective is to get the light source, and the test tube line up with spectroscop's input slit. The simplest way is to utilize a sliding mount 40-110, to allow up, and down adjustment of the test tube platform.

The result is a reliable test tube holder, and light source to line up with the slit input of the spectroscop. A thin plastic layer between 40-110, and the rods, provides variable height adjustment with adjustable friction.

On the next section, we are going to get into more sophisticated instrumentation with Optoform. These were child play just to get familiar with the basics.

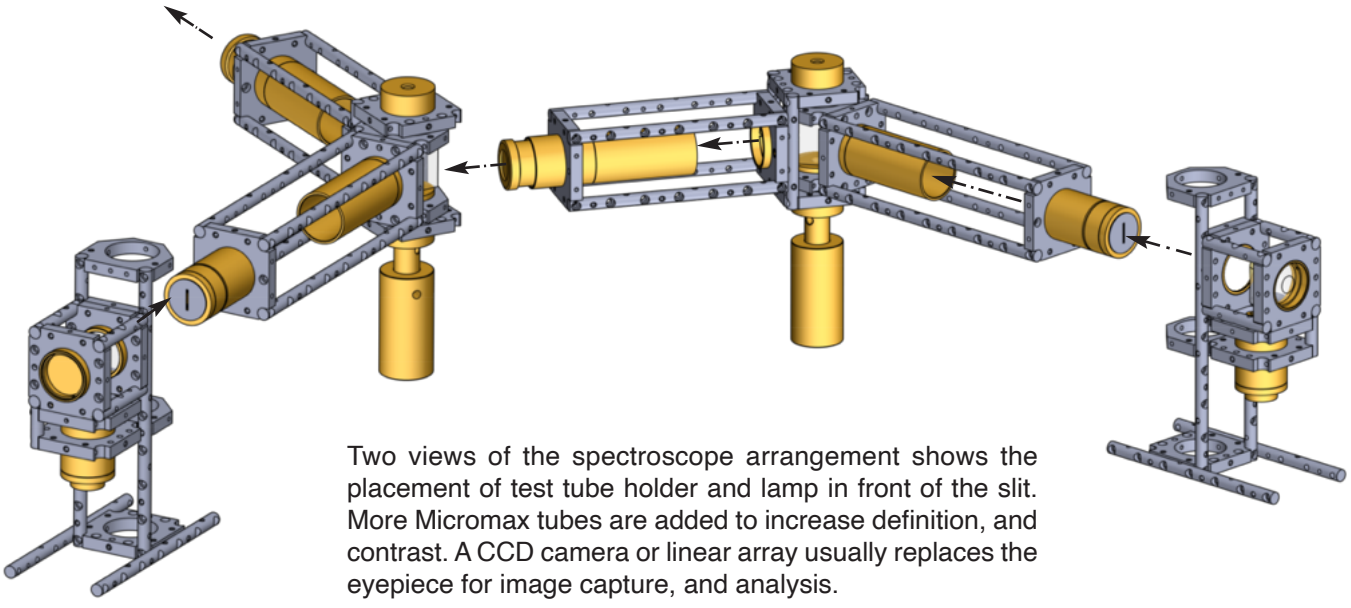
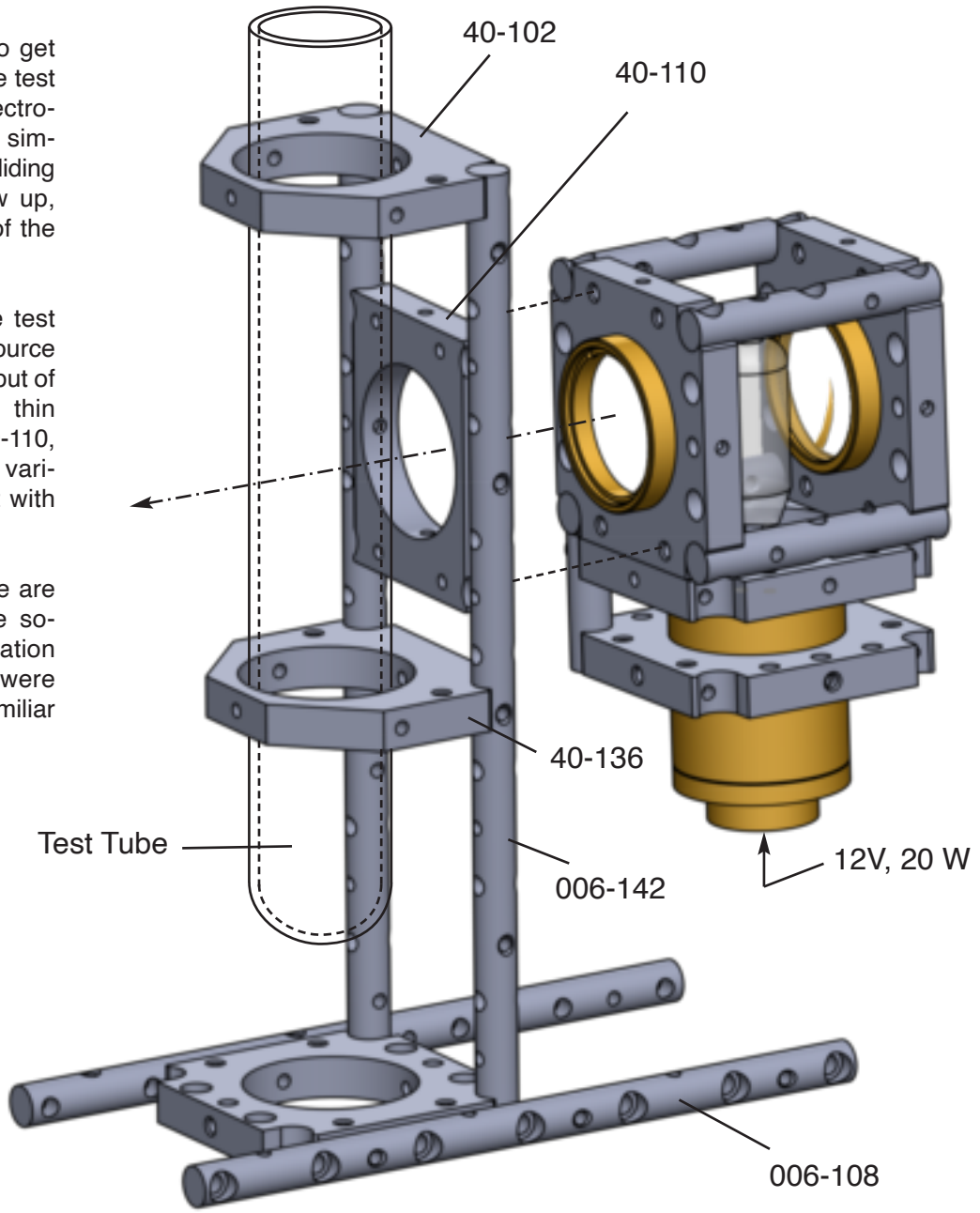

Two views of the spectroscopy arrangement shows the placement of test tube holder and lamp in front of the slit. More Micromax tubes are added to increase definition, and contrast. A CCD camera or linear array usually replaces the eyepiece for image capture, and analysis.

Small Optics Set 20-914

Part No	Description	Price	Quantity	Total
50-359	Lamp Socket 20/50W	105	1	105
130-102	Halogen Lamp 12v/50W	14	1	14
20-761	Slit, 1 mm	30	1	30
20-823	Eyepiece 10X	50	1	50
20-812	Microscope Objective 10X	120	1	120
20-442	Flat Mirror 25x38x3	30	1	30
20-450	Beamsplitter Mirror 25x38x2	34	1	34
20-412	Equilateral Prism 20x20x20	52	1	52
20-250	Condenser Lens $f = 18$	65	1	65
20-020	Plano Convex Lens $f = 100$	53	1	53
20-022	Plano Convex Lens $f = 150$	58	1	58
20-480	Concave Mirror $f = -10$	83	1	83
20-640	KG-1 Heat Absorbing Filter	44	1	44
20-SP	Kit Box	25	1	25
			Total Price	\$763

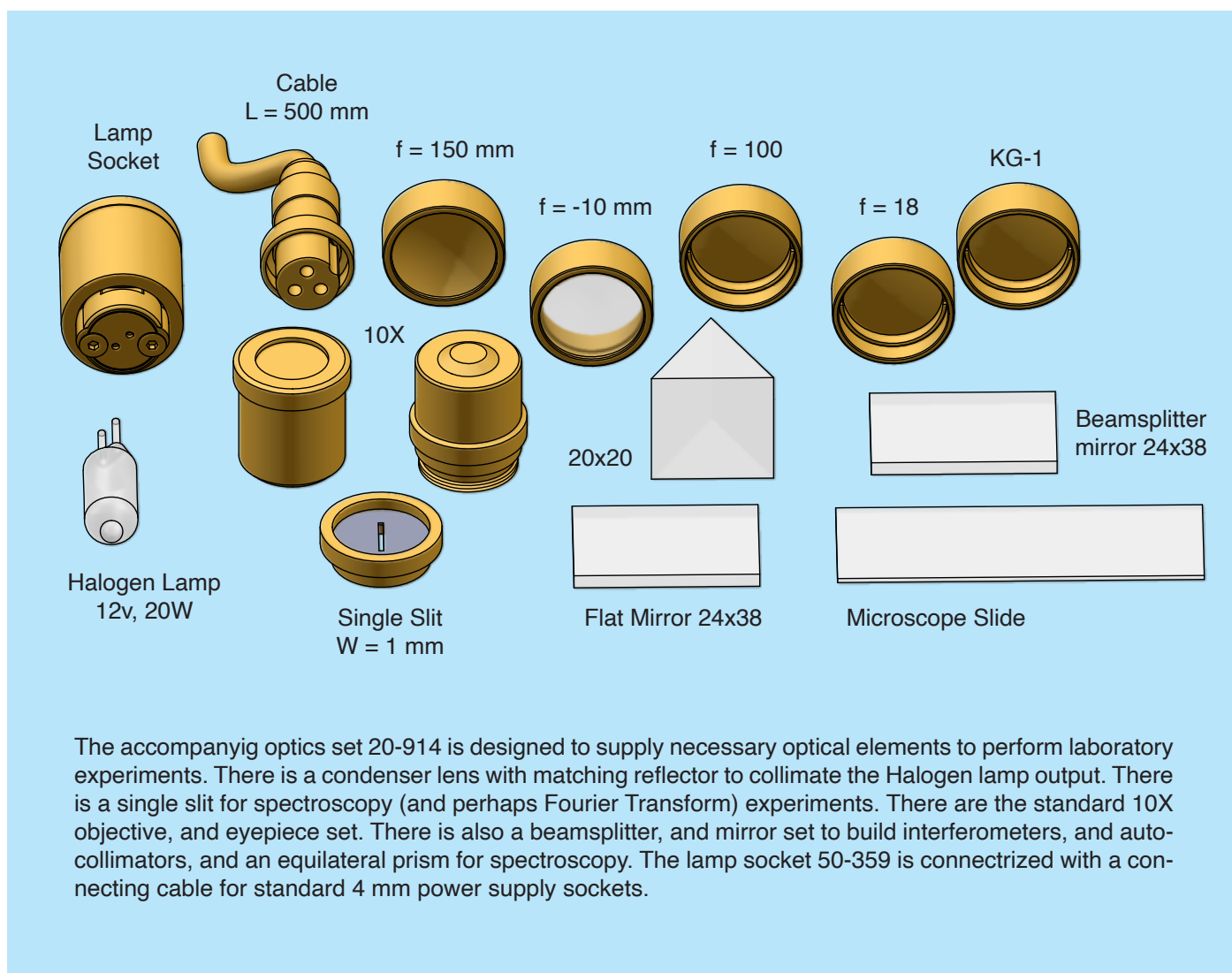

Optoform II Introductory Kit 40-706

The new Optoform Basic kit is designed to allow the end user to setup a multiplicity of optical experiments. The kit allows hands-on assembly of several optical instruments so its opto-mechanical capabilities could be studied. The rest is up to the user's own imagination, and creativity to build their own projects. First lets examine what's in this introductory kit, and then we'll start constructing from basic experiments such as a telescope, and we'll do more complex setups such as an autocollimator, and a spectroscope.

This kit is a mixture of parts from the Micromax system, some of Microptiic 50 accessories, and the new Optoform 40 mounting plates. There are plenty of rods to do many complex setups. Micromax tubing is utilized mainly for focusing of optical elements or to extend the optical path.

Part No	Description	Price	Quantity	Total
40-100	Standard Mount 25	\$20	4	80
40-102	Compact Mount 25	\$20	2	40
40-104	Angle Mount 25	\$20	4	80
40-106	Mating Plate 25	\$20	4	80
40-108	Intermediate Mount 25	\$23	1	23
40-110	Sliding Mount 25	\$25	1	25
40-130	Microbench Adapter 25	\$20	1	20
40-134	Side Mount 25	\$20	2	40
40-136	Side mount 25C	\$20	1	20
50-352	Titable Mirror Mount 25	84	1	84
50-331	Microscope Objective Mount 25	19	1	19
25-128	Tube 25, L = 30	25	2	50
25-130	Tube 25, L = 50	28	1	28
25-332	Microscope tube adapter	26	1	26
25-354	Eyepiece Holder 25	23	1	23
25-306	Extended Retaining Ring	9	3	27
25-198	Lens Cell Adapter	25	1	25
50-333	Post mount adapter M6	21	1	21
50-341	Post mount adapter 1/4-20	21	1	21
00-852	Sample Securing Spring Plate	25	1	25
006-20	Support Rod, L = 20	5	4	16
006-23	Support Rod, L = 23	5	2	10
006-40	Support Rod, L = 40	5	8	40
006-56	Support Rod, L = 56	6	2	12
006-74	Support Rod, L = 74	7	4	28
006-108	Support Rod, L = 108	8	4	32
006-142	Support Rod, L = 142	10	2	20
00-502	Cover Plate 34X34 mm	4	4	16
00-125	M2.5x6 Socket Head pack Of 100	25	1	22
00-126	M2.5x3 Set Screws pack Of 50	16	1	16
00-128	M2.5x6 Set Screws pack Of 50	16	1	16
00-129	M2.5x4 Cover Screws set of 20	10	1	10
00-248	Ball Driver set 1.25, 1.5, 2 mm	12	1	12
40-128	Spacer set 25/30x2.5 mm	12	1	12
20-SP2	Kit Case	35	1	35
			Total Price	\$1,076

New Optoform Kit is moderately arranged to allow performing various optical experiments. This kit is not only a starter kit but it can also be considered as an advanced set to perform many optical experiments to fulfill much higher level of expectations.

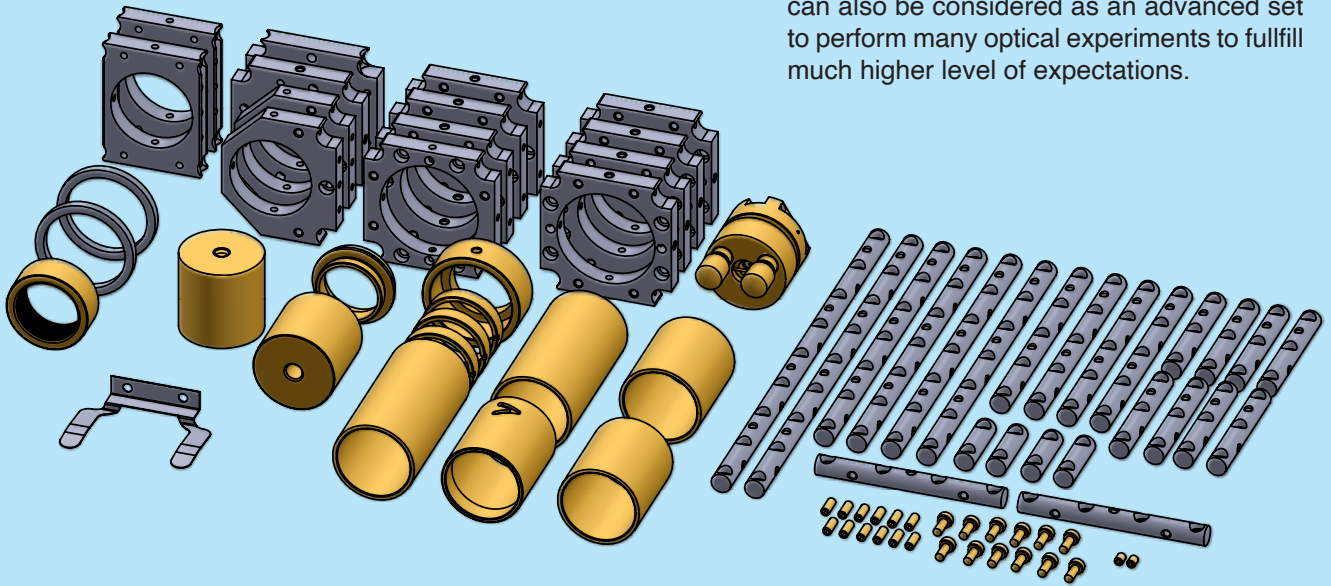

40-706 Optoform Starter kit contains 60 parts. Various lab setups can be performed such as building simple telescopes, or an autocollimator, and other applications such as microscopy, spectroscopy, etc.

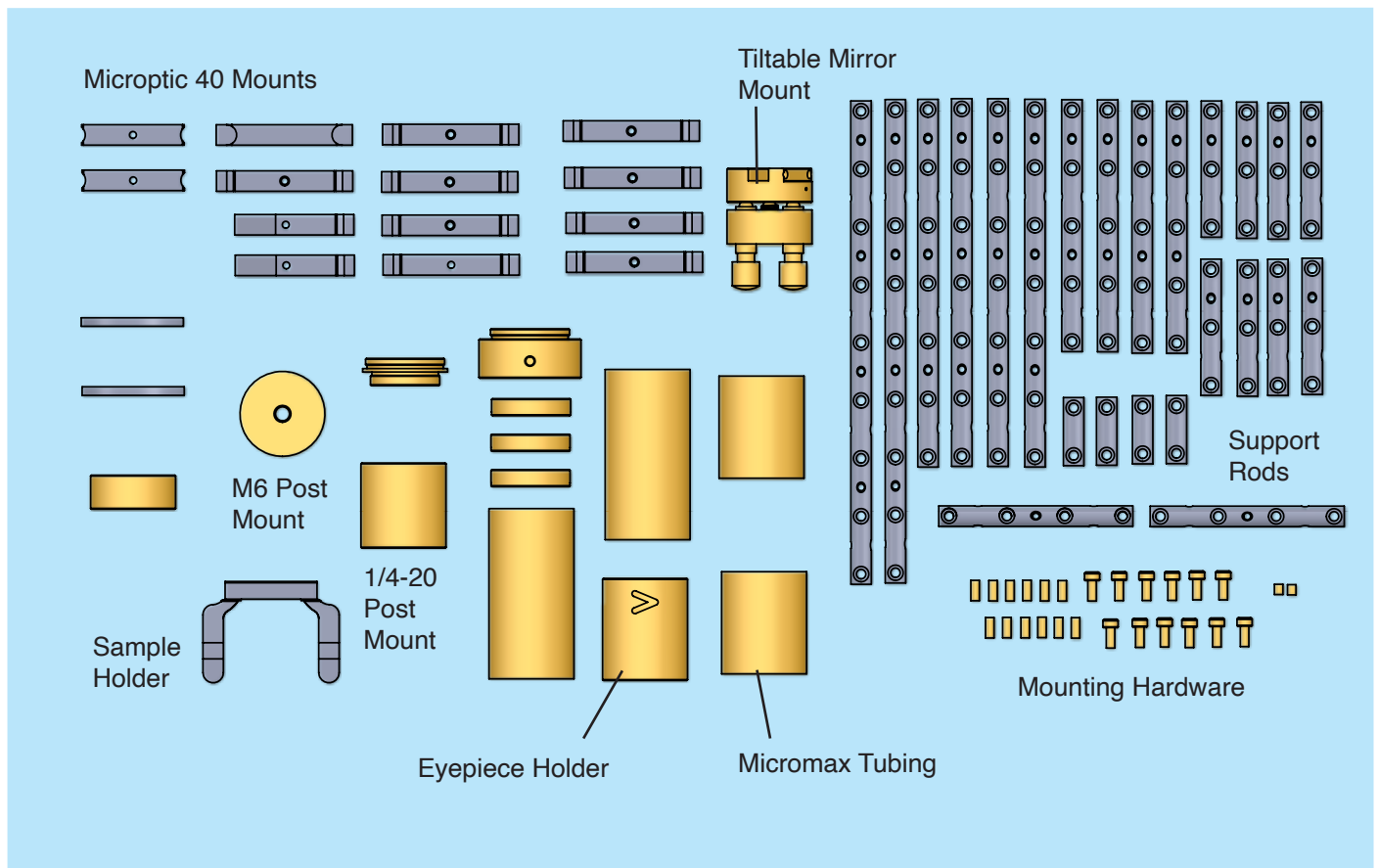

In the next pages, and the following issue, we will show how to set up these experiments, but the main goal is to prepare you to setup your own ideas, and be able to do problem solving in your own lab.

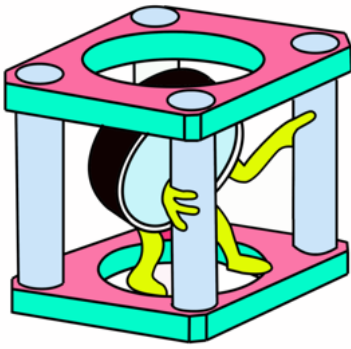

Other Cage Systems

Out of the cage system:

You can now use larger optics

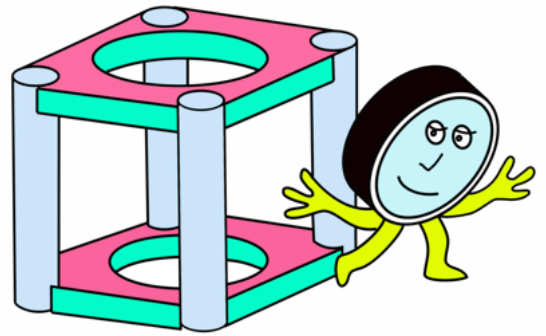

New Optoform

Placing support rods on the outside corners of Optoform mounts allows 25/30 mm mounted optics to be easily inserted, and taken out without obstruction. Up to 40 mm optics may now be fitted in between the rods.

Take apart, and reconfigure your designs with no limits

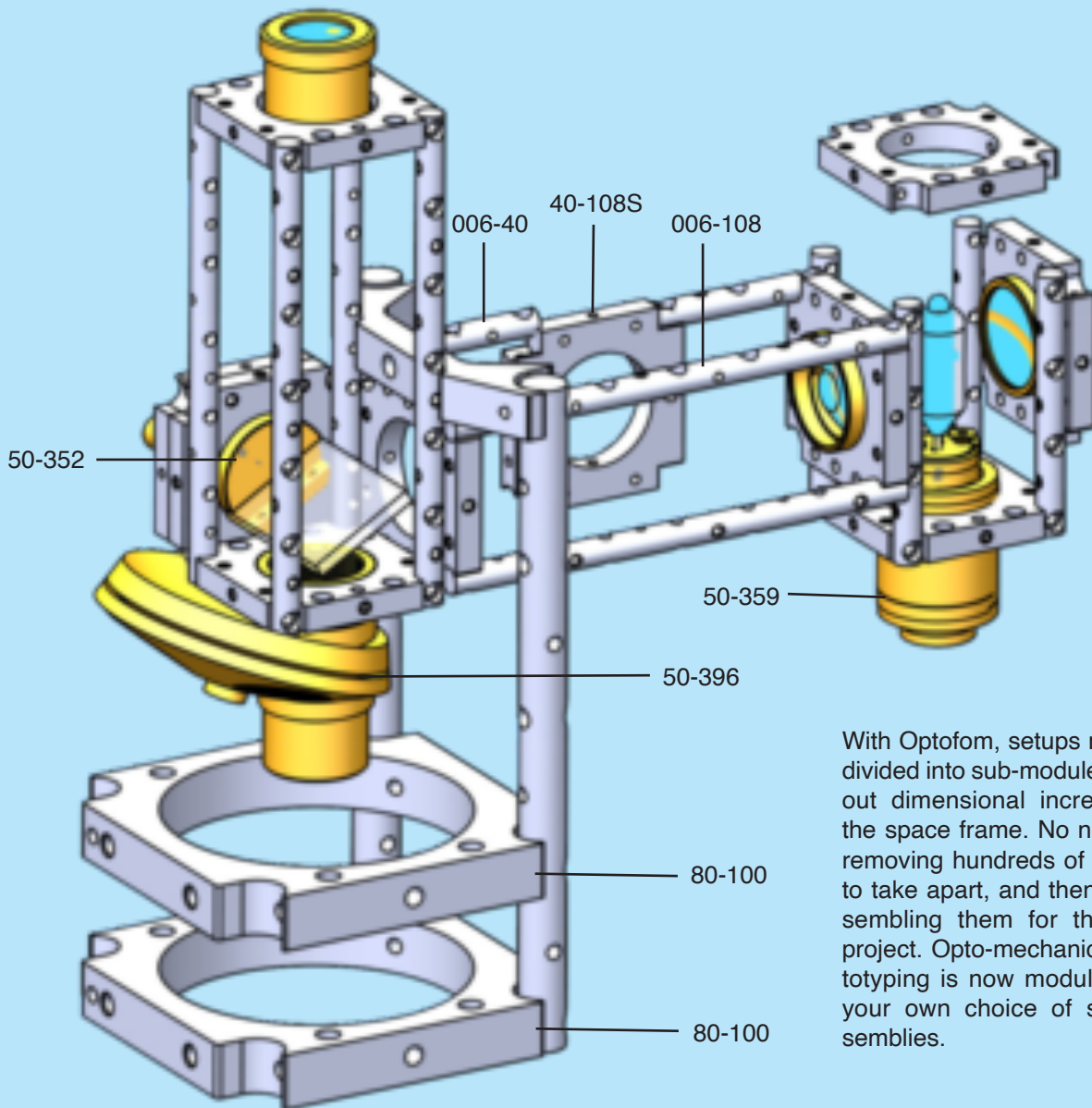

With Optoform, setups may be divided into sub-modules without dimensional increase of the space frame. No need for removing hundreds of screws to take apart, and then re-assembling them for the next project. Opto-mechanical prototyping is now modular with your own choice of sub-assemblies.