

Optomechanix

Optoform 40E

www.optoform.com

New Optoform II Cage System

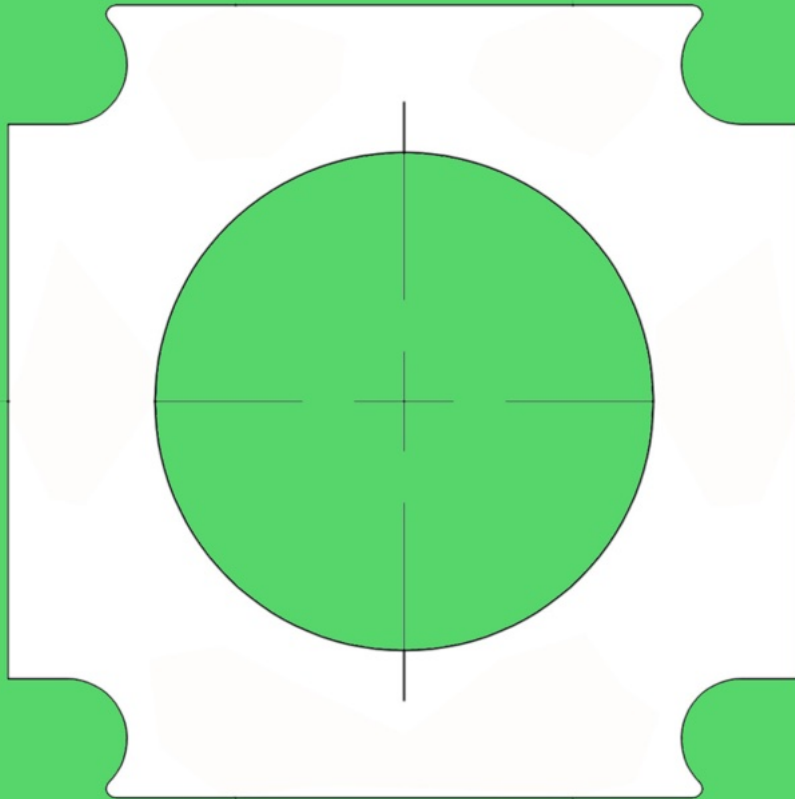

PCT Patent Pending US2019/020863
European WO 2020/180307, China 2021

Be Different. Think Different. Do it with Taste. Make it a better Product

The New Electro-Optics Lab

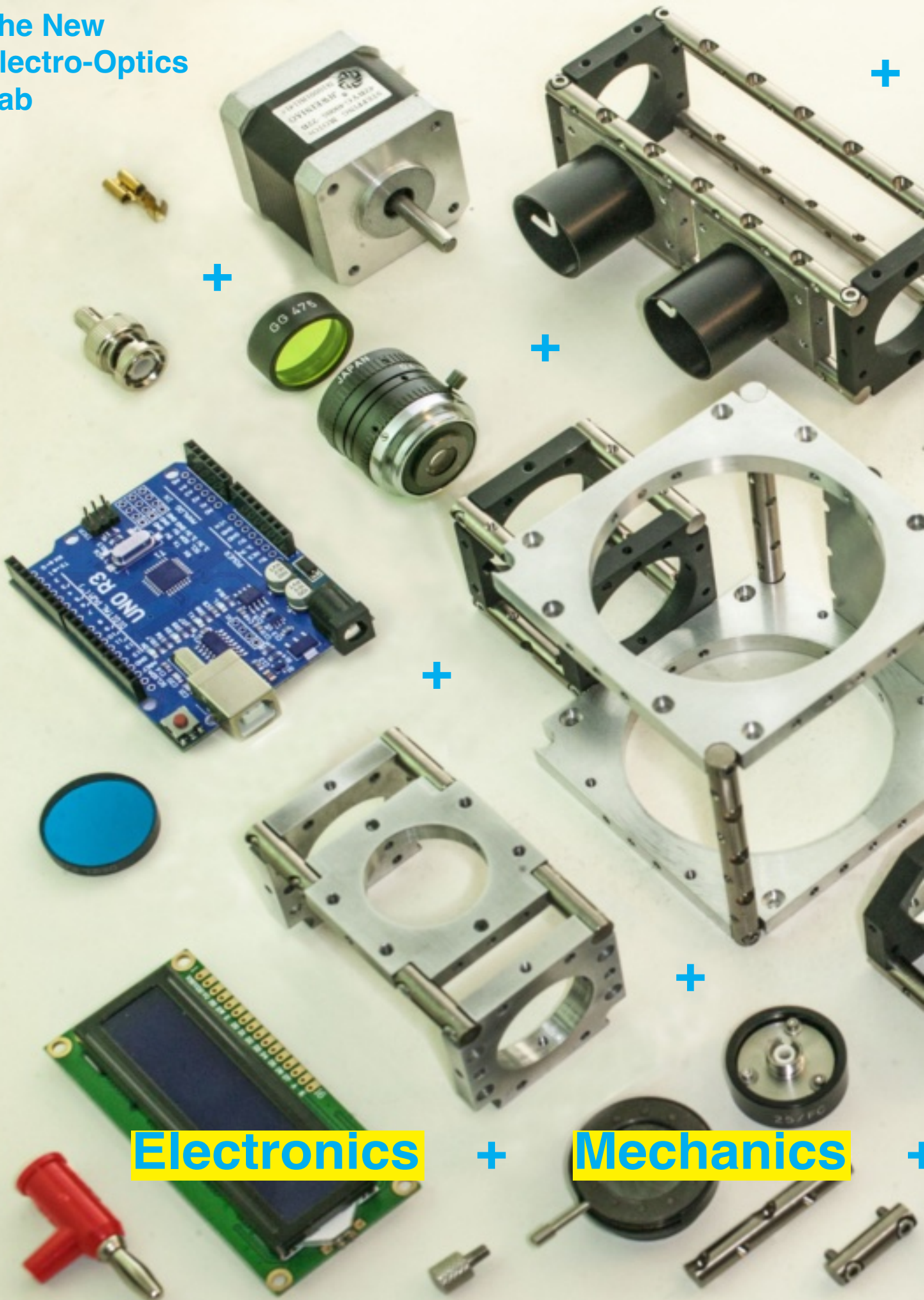

Electronics

+

Mechanics

+



New Optoform 40E, The low cost construction components for Electronics packaging, and Education

An optical cage system should bring something new, and honest to its end users. If you think you could just take off one rod, or change anodization colors, people will say no to it. Although a one-rod or three rod cage system is not as good as a 4-rod arrangement that's an engineering decision, not an innovative one.

So after nearly 30 years past my original design of Optoform in 1993, I said Optoform II better be something phenomenal or I won't spend time on it. Luckily, the new idea I had about making them cheaper, and more versatile, led me to design a new form that could be produced out of extruded Aluminum - a drastic reduction in manufacturing cost.

Before signing off an M&A agreement with Edmund Optics to hand over Optoform I, we had been manufacturing it for 18 years. I know it takes a 5-axis CNC machine around 5 minutes to produce each mount. This drives the price to \$30 each. New Optoform II can be produced in a quarter of that time, and a quarter of the cost.

Since Optoform II is less expensive, thinner, and lighter, you could divide your setups into sub-assemblies. Optoform II offers space frame components so you could build complete housings, and portable instruments. In upcoming pages, we'll review some real applications, and see how the new Optoform building blocks can be helpful in constructing them. These are culmination of many applications notes previously published in our quarterly magazine at optomechanix.org.

Ali Afshari
CEO, Optomechanix

Main Design Advantages: Less expensive, more versatile, more compact, lighter weight, more rigid, accepts larger optics, allows assembly from modules, could use various size rods.

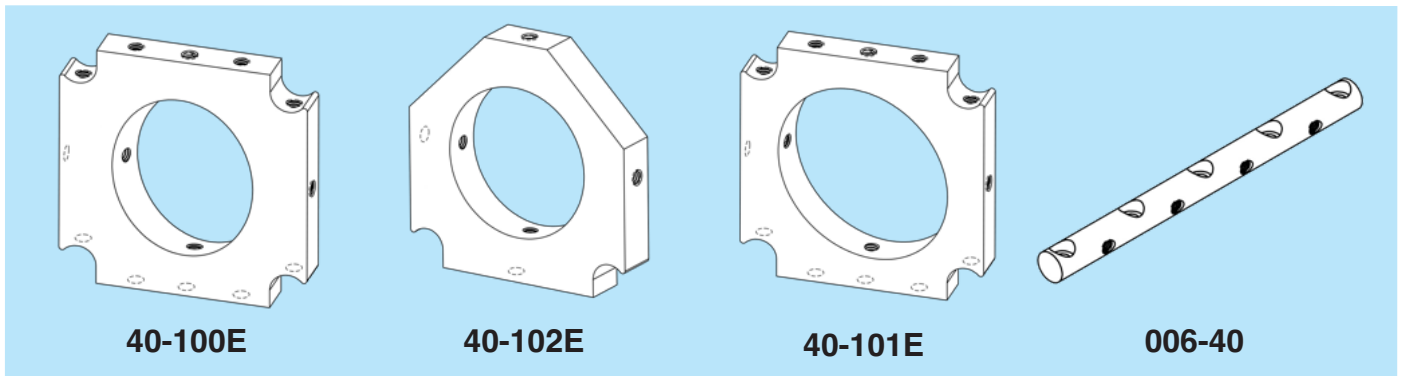

Optoform mounts 40-100E, and 40-104 with 25 mm clear apertures, 40-101E with 30 mm clear aperture, and support rod 006-40

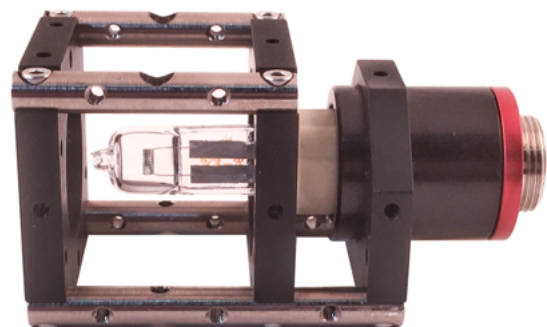
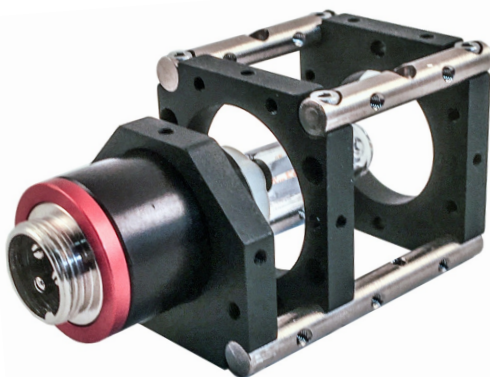

Microscope Housing with a Single Detector

A comparison between building with machined parts vs Optoform

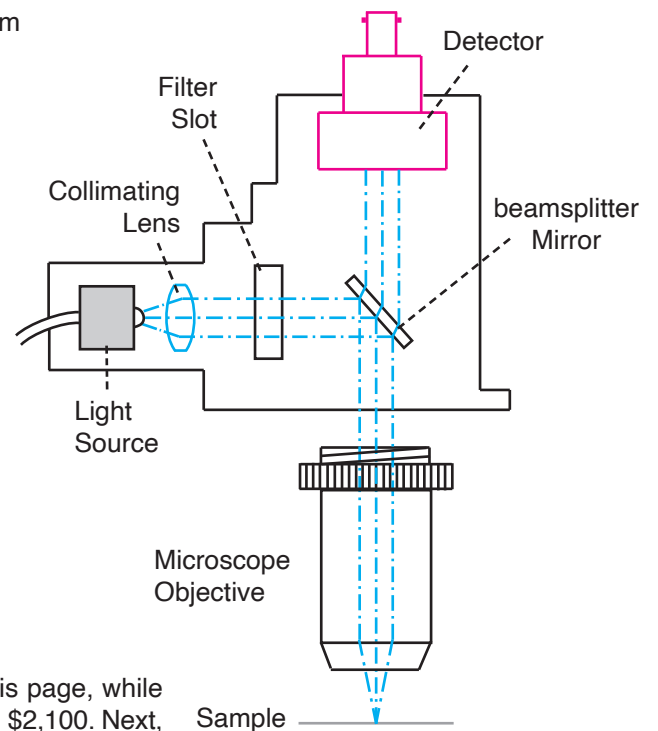

A scanning microscope is built with machined parts shown on this page, while not being able to change the final assembly. Total cost for housing \$2,100. Next, the same assembly is built utilizing off-the-shelf Optoform components. It's 50% lighter, and the final design can be rearranged. Total cost of housing \$325.

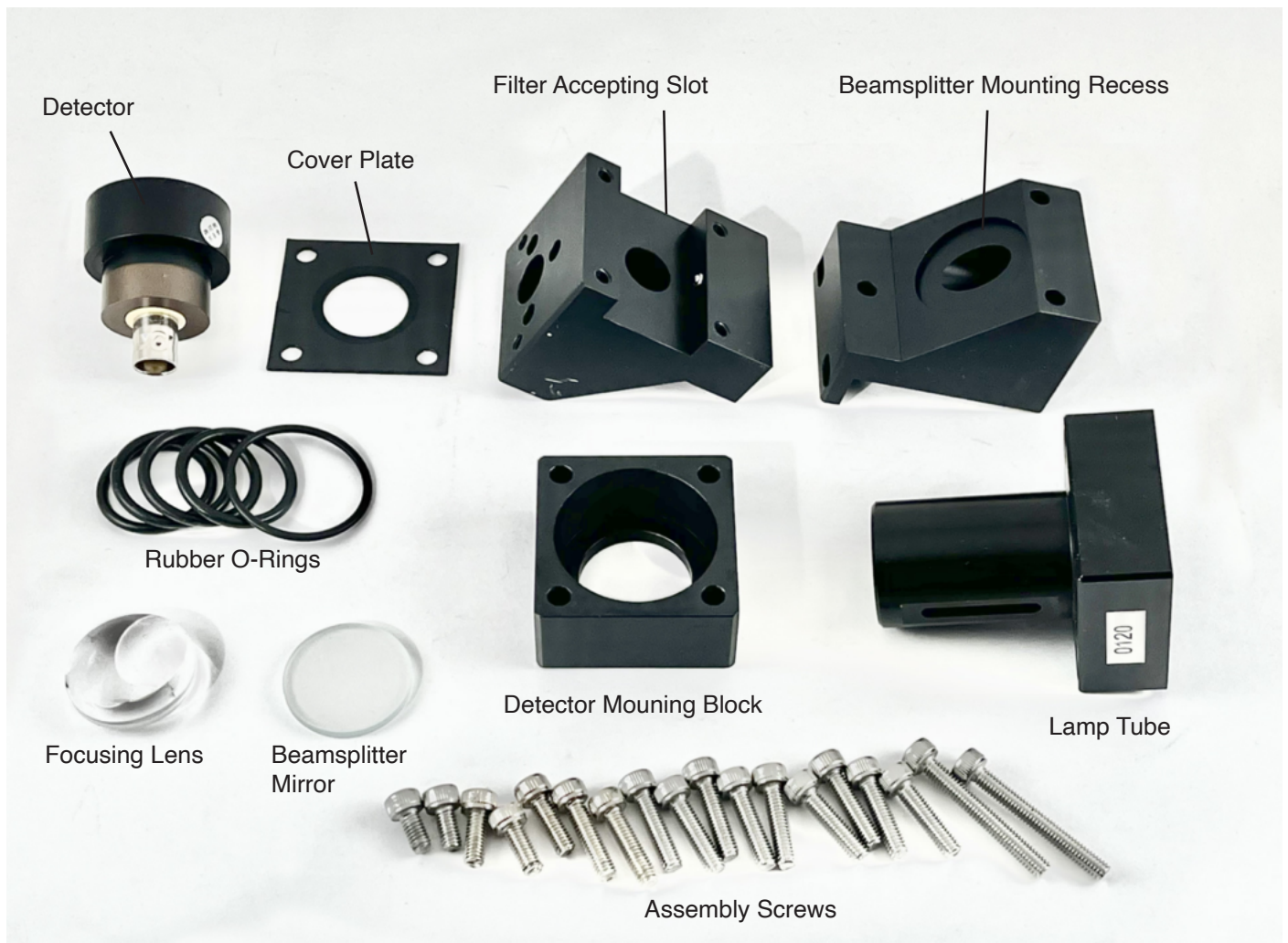

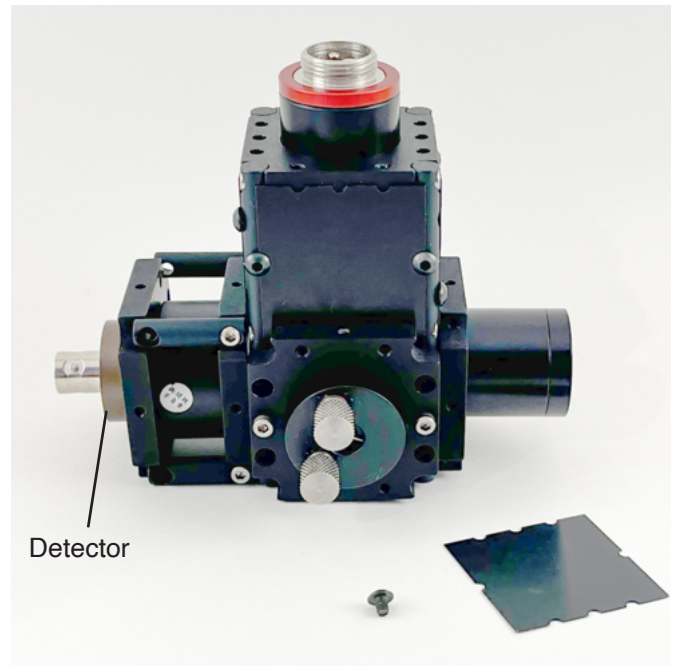
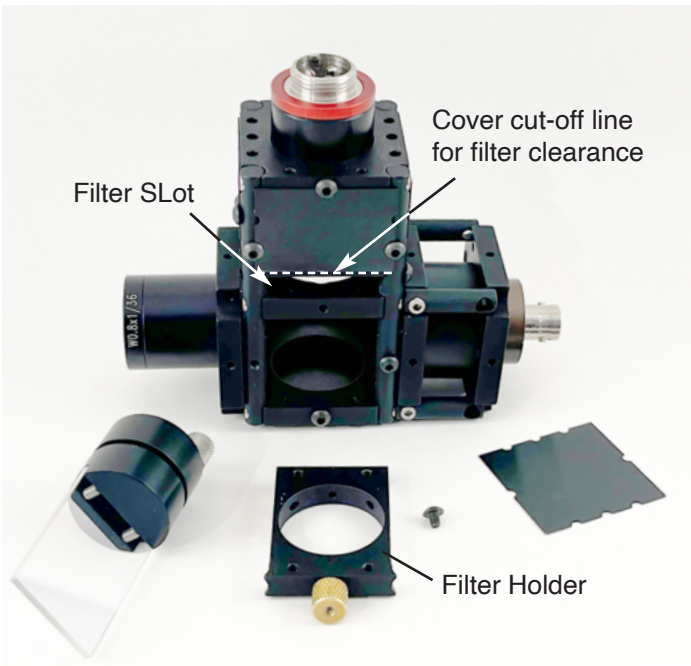

Left, further assembly with beamsplitter, and filter holder still out, Right, below, fully assembled with one cover plate off.

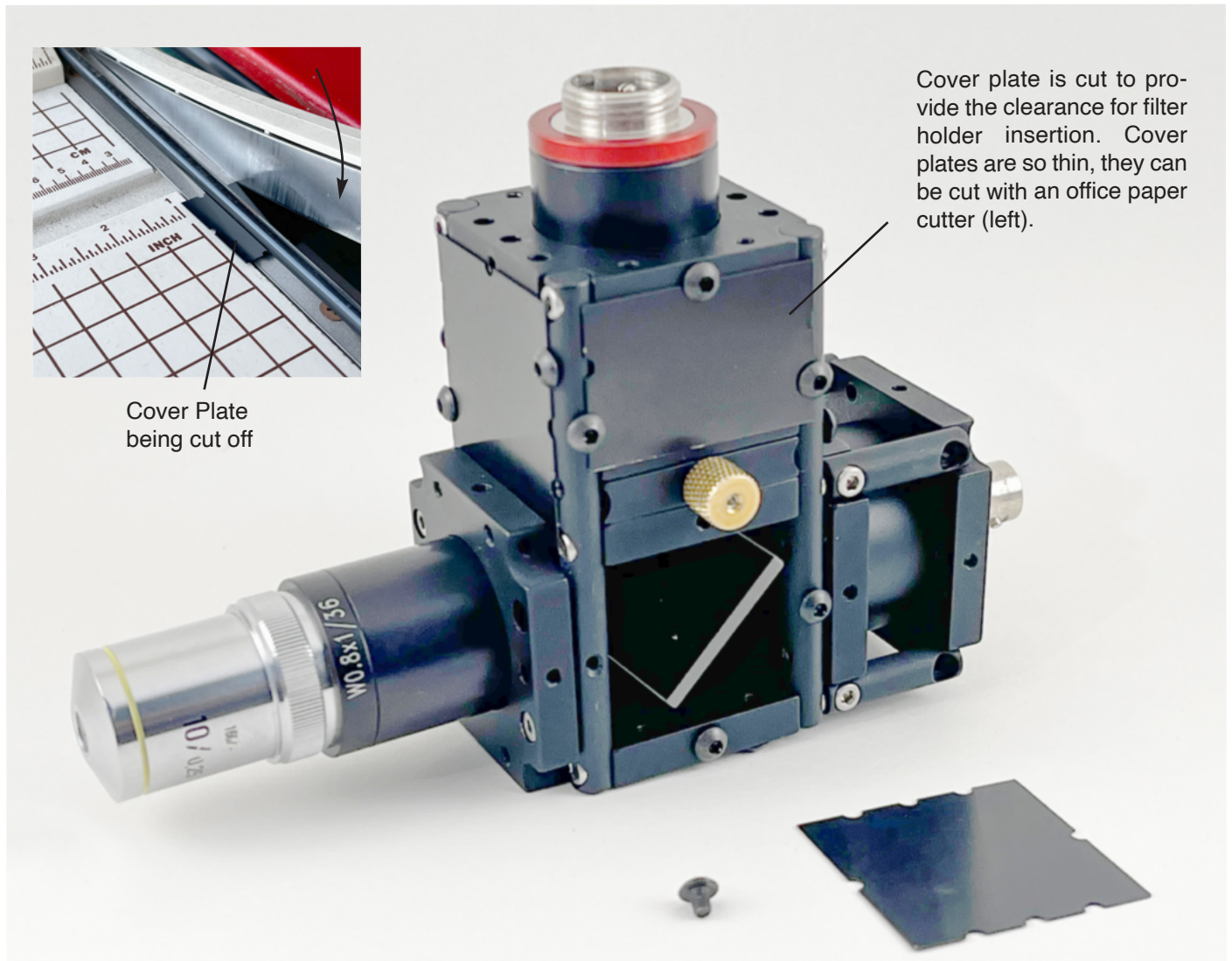

Fully assembled setup with a 10X microscope objective ready to use. Cover plate remains off to show the beamsplitter.

Optoform 40E Opto-mechanical Componets and accessories

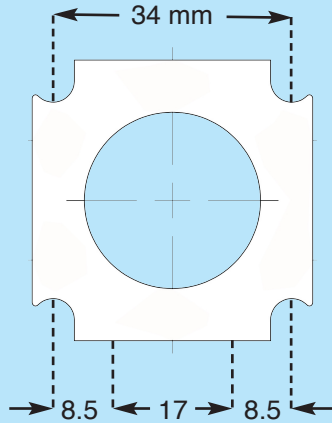
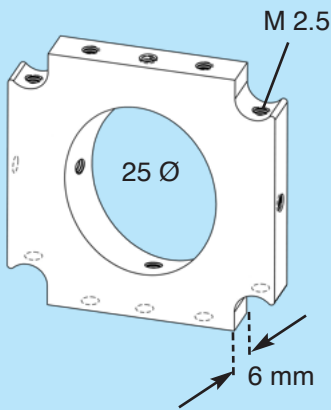

40-100E Standard Mount 25

Basic building block for optical setups with 25 mm mounting bore to secure 25 mm mounted optics, and accessories. May be mounted on support rods via M2.5 screws. The threaded bore pattern on the edge of these mounts matches the 17 mm bore pattern on support rods.

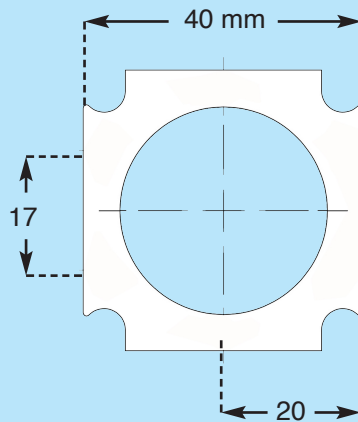
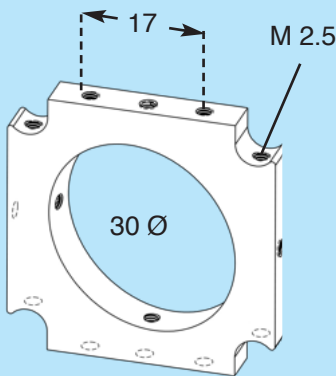

40-101E Standard Mount 30

Identical to 40-100E but with 30 mm clearance aperture to secure 30 mm mounted optics, or accessories.

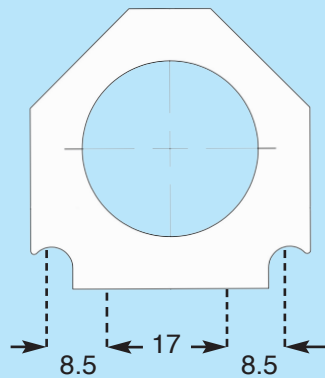
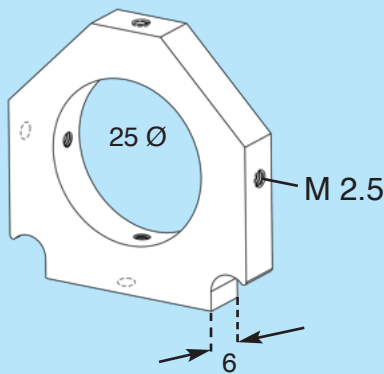

40-102E Right Angle Mount 25

Identical to 40-100E but for a more compact 2-rod assembly. May be utilized with 40-100 mounts in two pairs for angular adjustments between two rod assemblies.

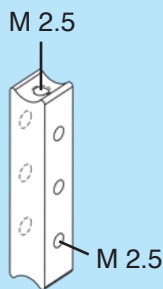

40-CC4

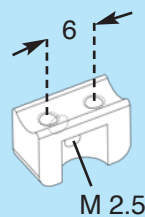

40-CC2

40-CC2 CORNER CONNECTOR

Allows a T joint or end to end connection between 2 or 3 support rods via M2.5 allen screws.

40-CC4 CORNER CONNECTOR

Can be secured in between two parallel rods where needed in creating space frame assemblies

Support Rods

Aluminium Alloy	Stainless S
006-12 , L= 12 mm	Special Order
006-20 , L= 20 mm	
006-23 , L= 23 mm	
006-40 , L= 40 mm	
006-50 , L= 50 mm	
006-57 , L= 57 mm	
006-65 , L= 65 mm	
006-74 , L= 74 mm	006-74S
006-80 , L= 80 mm	006-80S
006-108 , L= 108 mm	006-108S
006-128 , L= 128 mm	006-128S
006-142 , L= 142 mm	006-142S

Mounting Hardware

00-116	M2.5x10 Thumb screws, pack of 5	For securing accessories on M2.5 threaded bores
00-120	M2.5x10 Low profile, 25 pcs	For securing two mounts face to face
00-125	M2.5x6 Socket screws, 100 pcs	Standard rod securing screw
00-126	M2.5x3 Set screws, pack of 100	Optics securing screws, L = 3 mm
00-128	M2.5x6 Set screws, pack of 100	Optics securing screws, L = 6 mm
00-129	M2.5x4 low profile, 25 pcs	For sheet covering around Optoform 40 assemblies
00-222	M2.5 Nut, set of 10	For securing accessories along M2.5 set screws
00-248	Ball driver set 1.27, 1.5, 2 mm	For constructing Optoform 40, and 74 assemblies
006-40F	6 mm rod, L = 40 mm, set of 12	Special 6 mm rods with M2.5 threaded ends, with detent

Cover Plates

Sheet covering in Optoform may be easily cut to size by household shears or office paper cutters. There are also nibbling tools available to provide clearance notches for mounting screws.

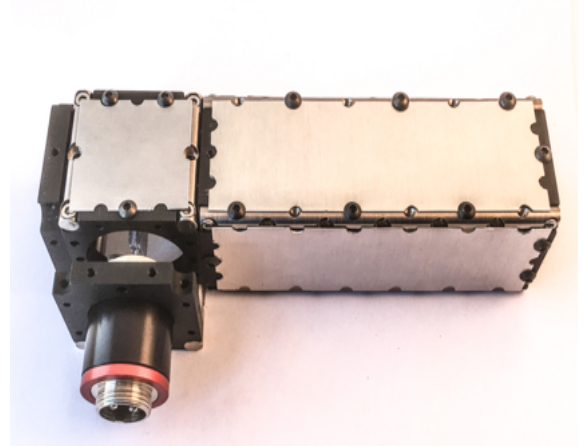
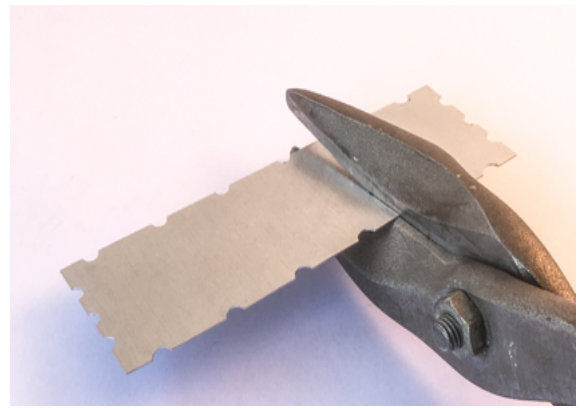
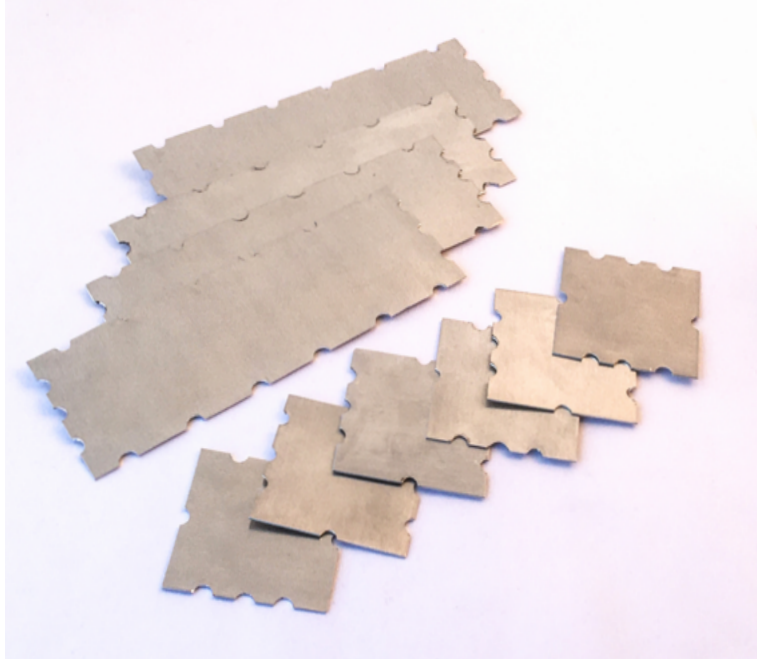

00-500	14 X 34 mm, 0.3 mm Thickness	For covering 20 X 40 space frames
00-502	34 X 34 mm, 0.3 mm Thickness	For covering cube 40 X 40 faces
00-504	34 X 51 mm, 0.3 mm Thickness	For covering 40 X 57 space frames
00-506	34 X 68 mm, 0.3 mm Thickness	For covering 40 X 74 space frames
00-508	34 X 102 mm, 0.3 mm Thickness	For covering 40 X 108 space frames
00-510	34 X 136 mm, 0.3 mm Thickness	For covering 40 X 142 space frames
00-512	68 X 68 mm, 0.3 mm Thickness	For covering cube 74 X 74 space frames
00-514	68 X 102 mm, 0.3 mm Thickness	For covering 74 X 108 space frames
00-516	68 X 136 mm, 0.4 mm Thickness	For covering 74 X 142 space frames
00-518	68 X 120 mm, 0.4 mm Thick, Set of 2	Special 74 X 126 binocular head's top cover
00-520	68 X 102 mm, 0.4 mm Thickness	For covering 74 X 80 linear bearing assembly

Cover plates are cut at the center-line of M2.5 screw bore pattern around their periphery. This allows cover plates to lay side by side around the space constructed by mounting plates, and support rods. In optoelectronics projects, cover plates may be drilled, and nibbled to secure electronics connectors, and switches. The standard color for cover plates is anodized light gray. Unanodized version of cover plates are also available to take any desired color.

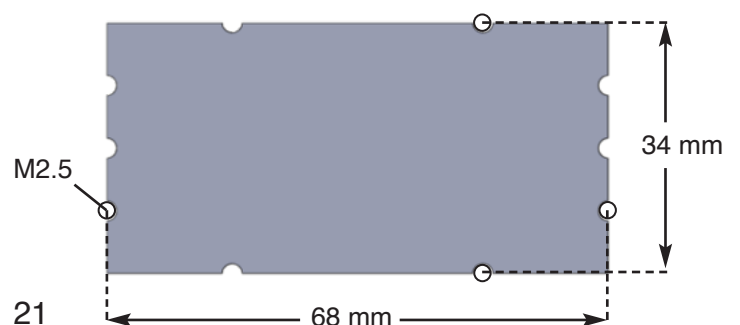

From basics all the way to highly advanced setups: Building a Telescope

You'll be able to construct these examples such as this simple telescope with parts from the basic **Basic Optoform kit 40-706**. This kit contains some Micromax parts such as an eyepiece holder (25-354), and an objective holder (25-198). The objective holder secures 25 mm mounted lenses such as $f = 150\text{mm}$ (20-022) from the **Basic Optics Kit 20-914**. All our 25 mm lens cells can screw directly to Micromax tubing (25-128 or -130) but the 150 mm plano convex lens faces the wrong direction. This is how the lens cell adapter 25-198 becomes useful. Other tubes could also mate together via retaining rings 25-306, such as eyepiece holder 25-354, and tube 25-128 as shown below.

We'll use two mounting plates 40-100, and 40-106 to secure the eyepiece at one end, while securing the objective at the other. Optoform 40 assemblies are built like stackable cages, to allow their reconfiguration in the most modular way. The focusing is performed within the mounts via Micromax tubing.

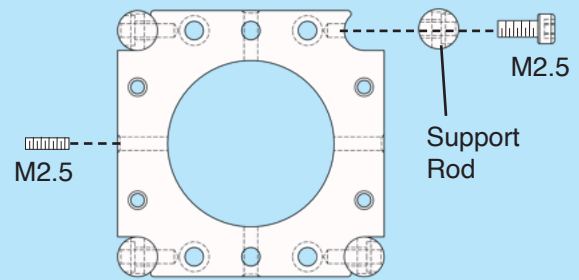
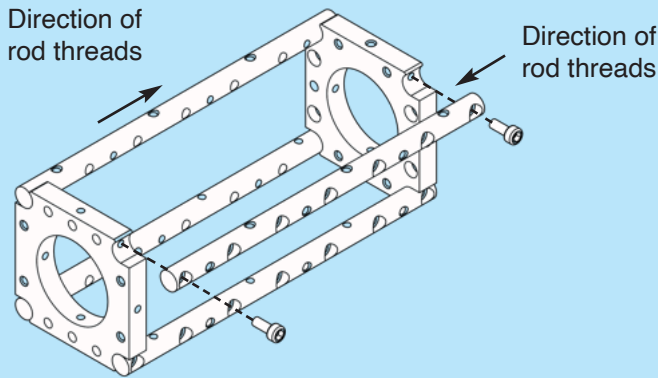
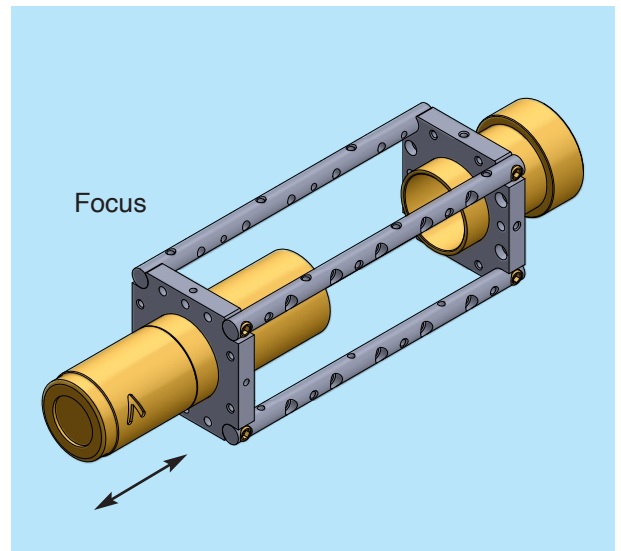

Cross section of mount 40-100

Above, what not to do in assembling odd sized rod lengths..

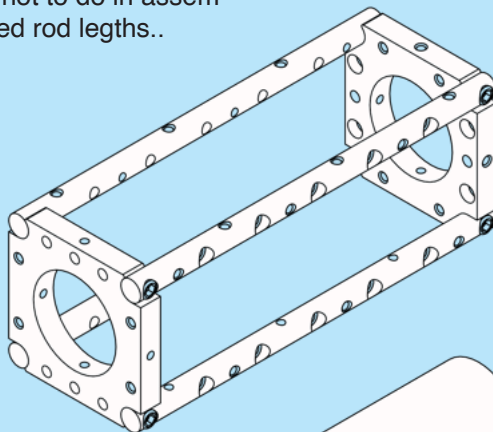

if rods are mounted in random direction, the likelihood of finding covering would decrease.

(10X Eyepiece)

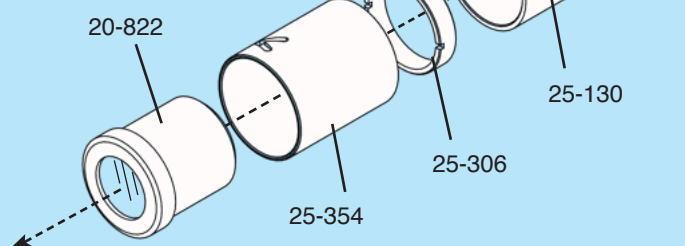

(Objective)

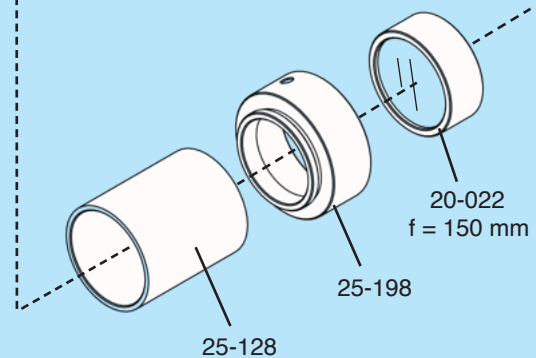

Telescope with right angle viewing

The advantage of Optoform's modularity can now be examined when building this simple telescope with right angle viewing. Basically, we'll take out the eyepiece of the first telescope we built, and build a cube around it and a mirror holder to bend the light 90 degrees.

Optoform 40 is so compact that we need to extend it on one end to secure the existing mirror holder 50-352, and be able to center the mirror on the main optical axis.

There are several ways to accomplish this. We'll try the quickest method (Shown below), and that is to stack two mounts together: 40-100S, and 40-106. The 40-100S provides the tilt clearance for mirror mount 50-352 while the stationary end is being held by 40-106.

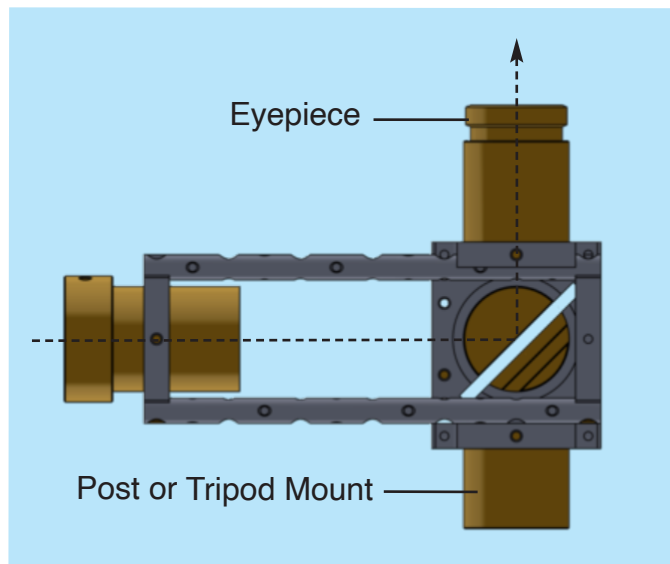

This telescope gives an upright image orientation, and much better user comfort around the lab.

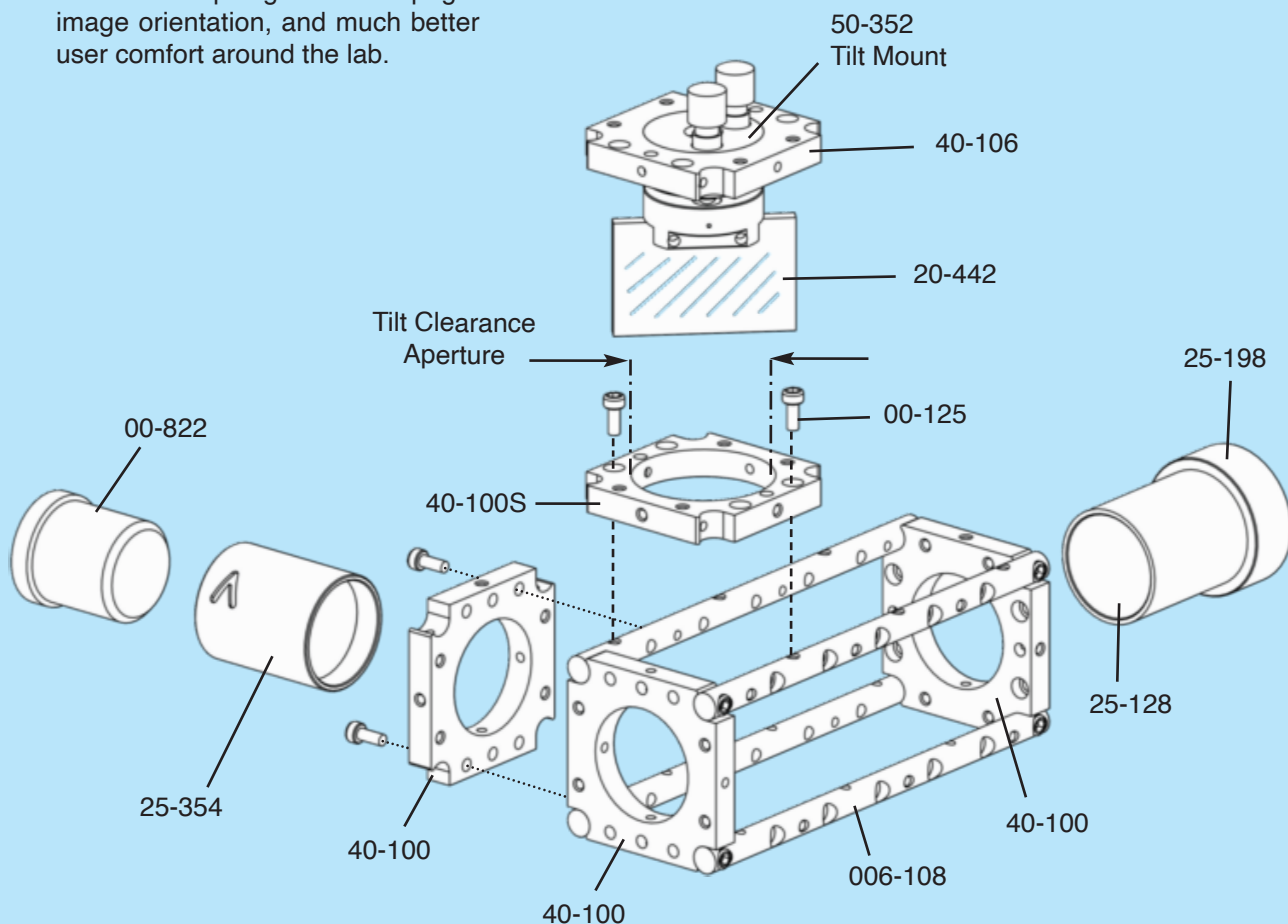

The back end of tiltable mirror mount 50-352 is held by 40-100 while its front end is given space for its tilt adjustment inside the 30 mm clearance aperture of 40-100S.

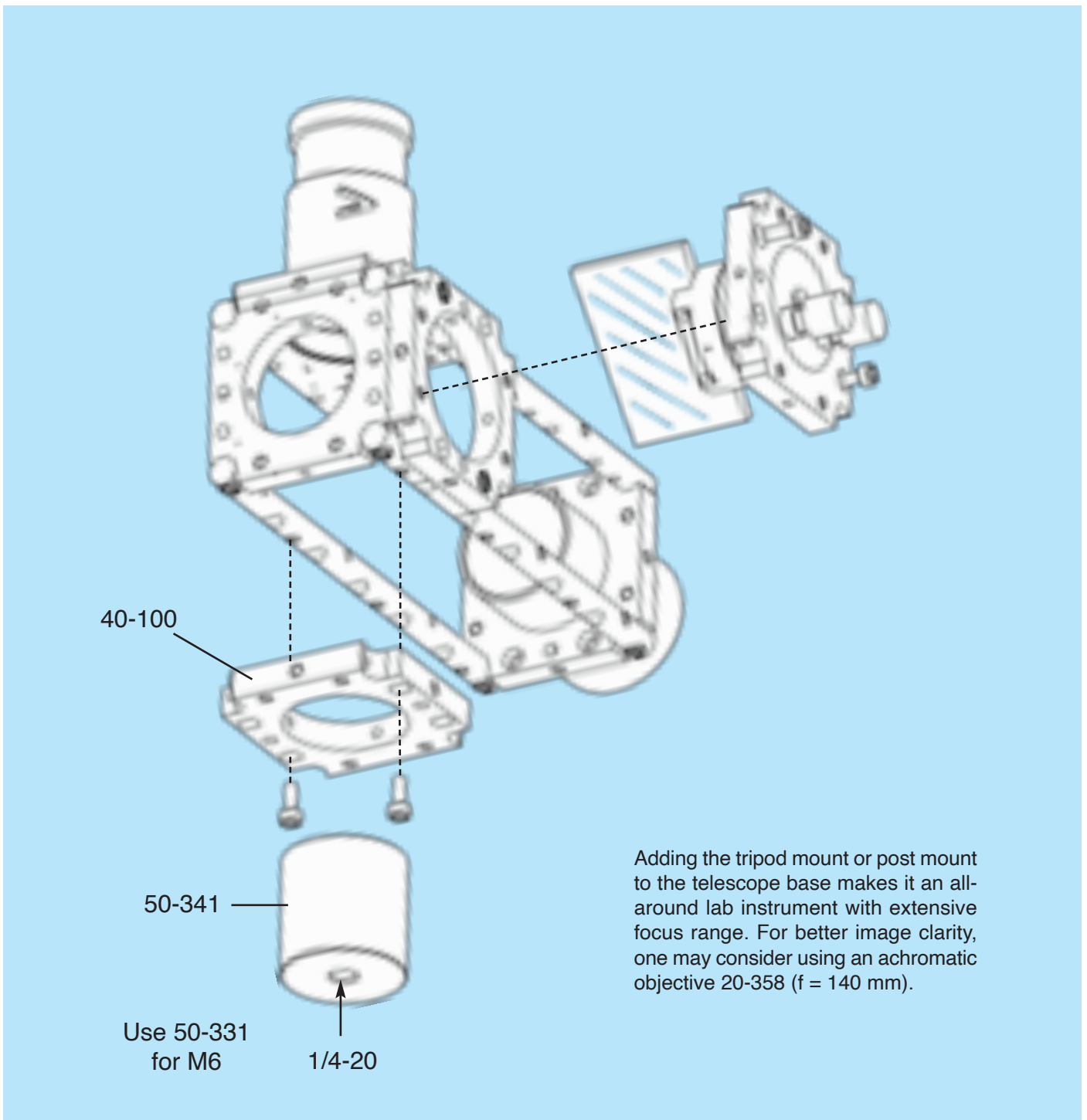
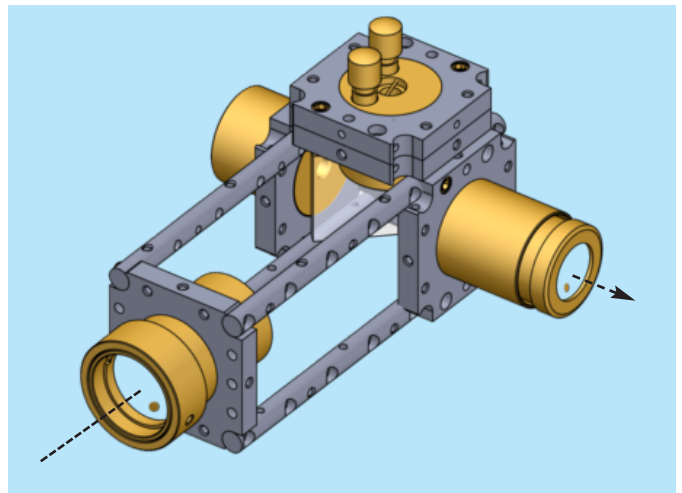
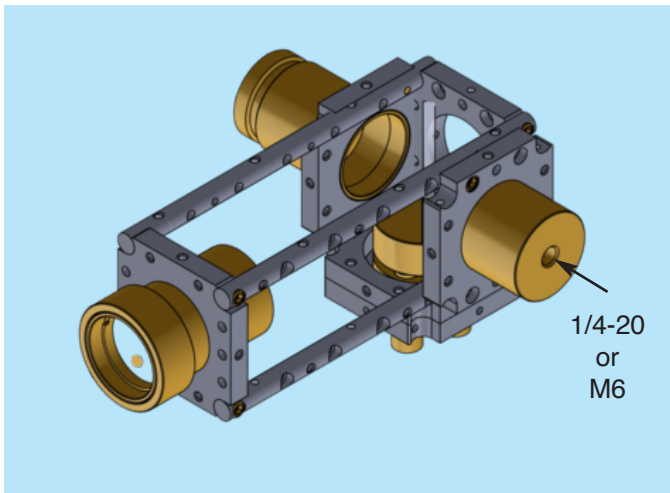

Building a Halogen Lamp Housing

Before building microscopes, we'd better start with a lamp housing. Halogen is the most widely used light source other than LEDs.

The collimating optics 20-250, and concave mirror 20-480 are oriented in their lens cells such that Micromax extension tubes may be added to position them closer to the lamp (below). The Halogen beam is collimated, then focused to the sample by an additional lens (An optional double convex lens 20-108, $f = 16 \text{ mm}$ is recommended).

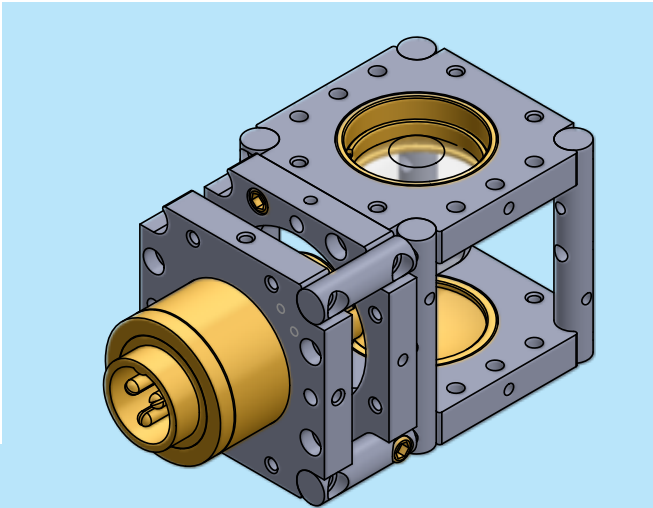

Halogen Lamp Assembly

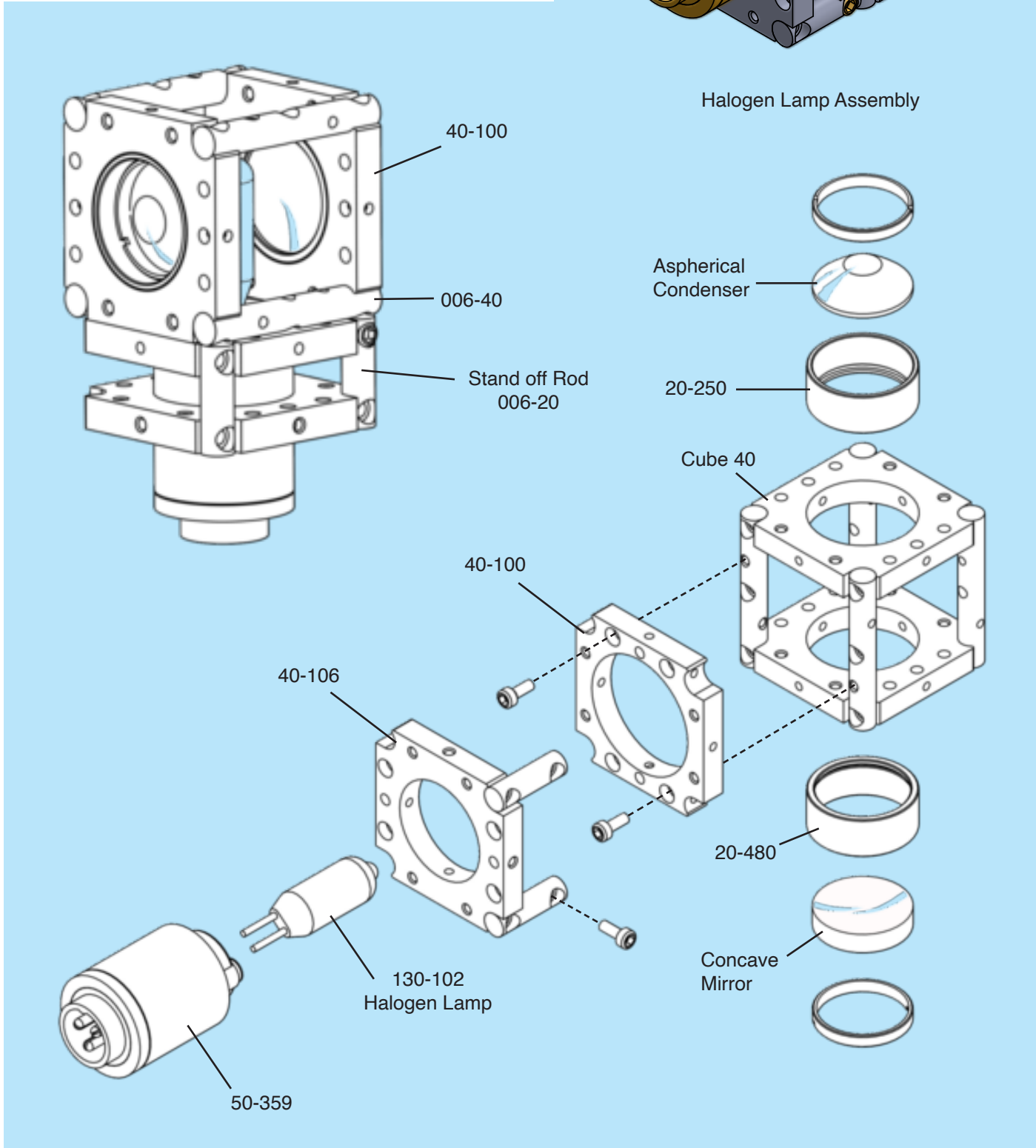

Building a Biological Microscope

Now that we have a proper light source, let's construct the microscope body. For standard microscope objectives, we need a 160 mm long tube. This is constructed by adding Micromax tubes 25-128, 25-130, and the eyepiece holder 25-354. The four tubes are joined together by three extended retaining rings 25-306. The objective mounting ring is assembled by adding 50-331, and 25-332 to the bottom of the tube. Sample holder spring plate 00-852 secures standard microscope slides.

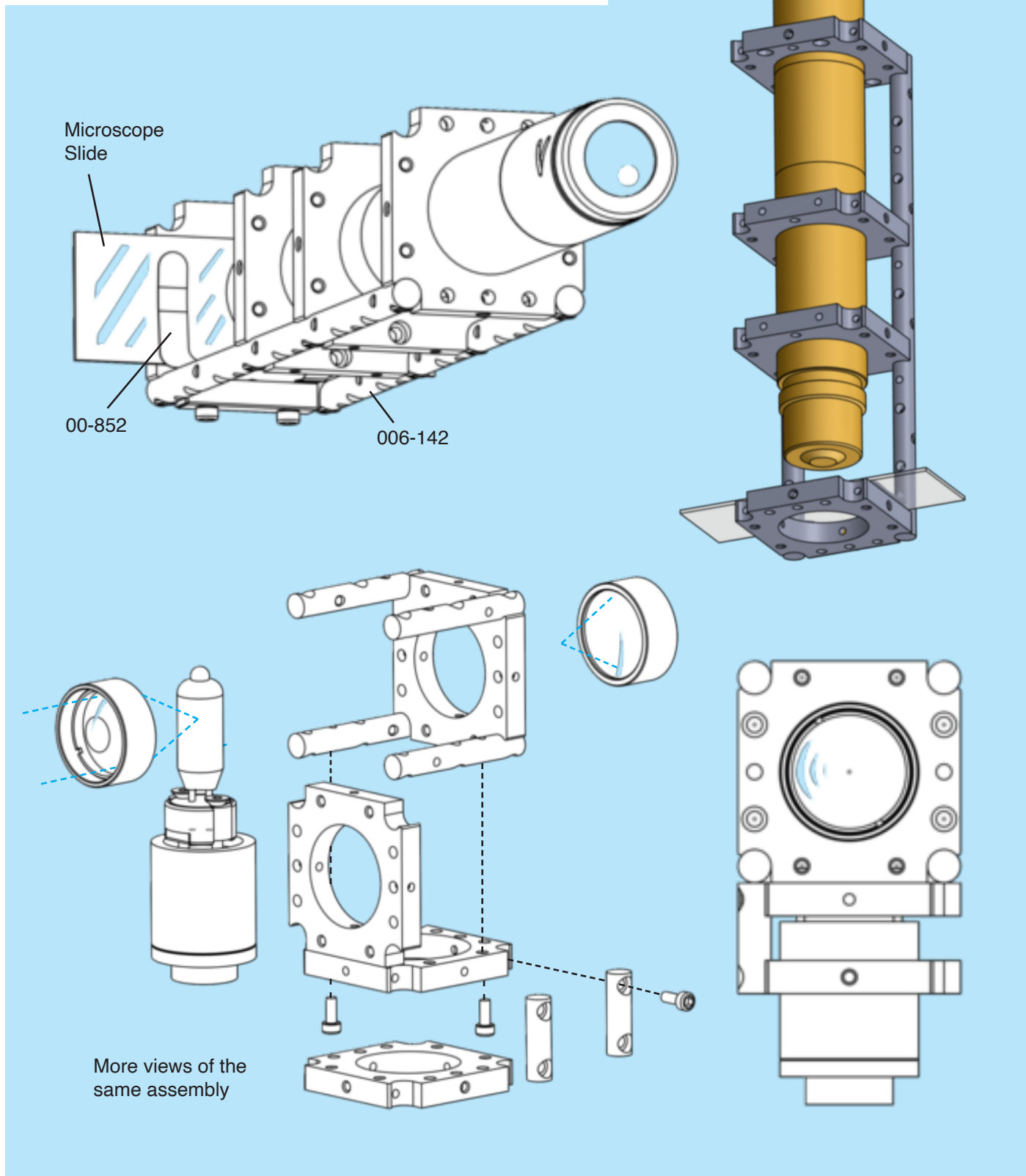

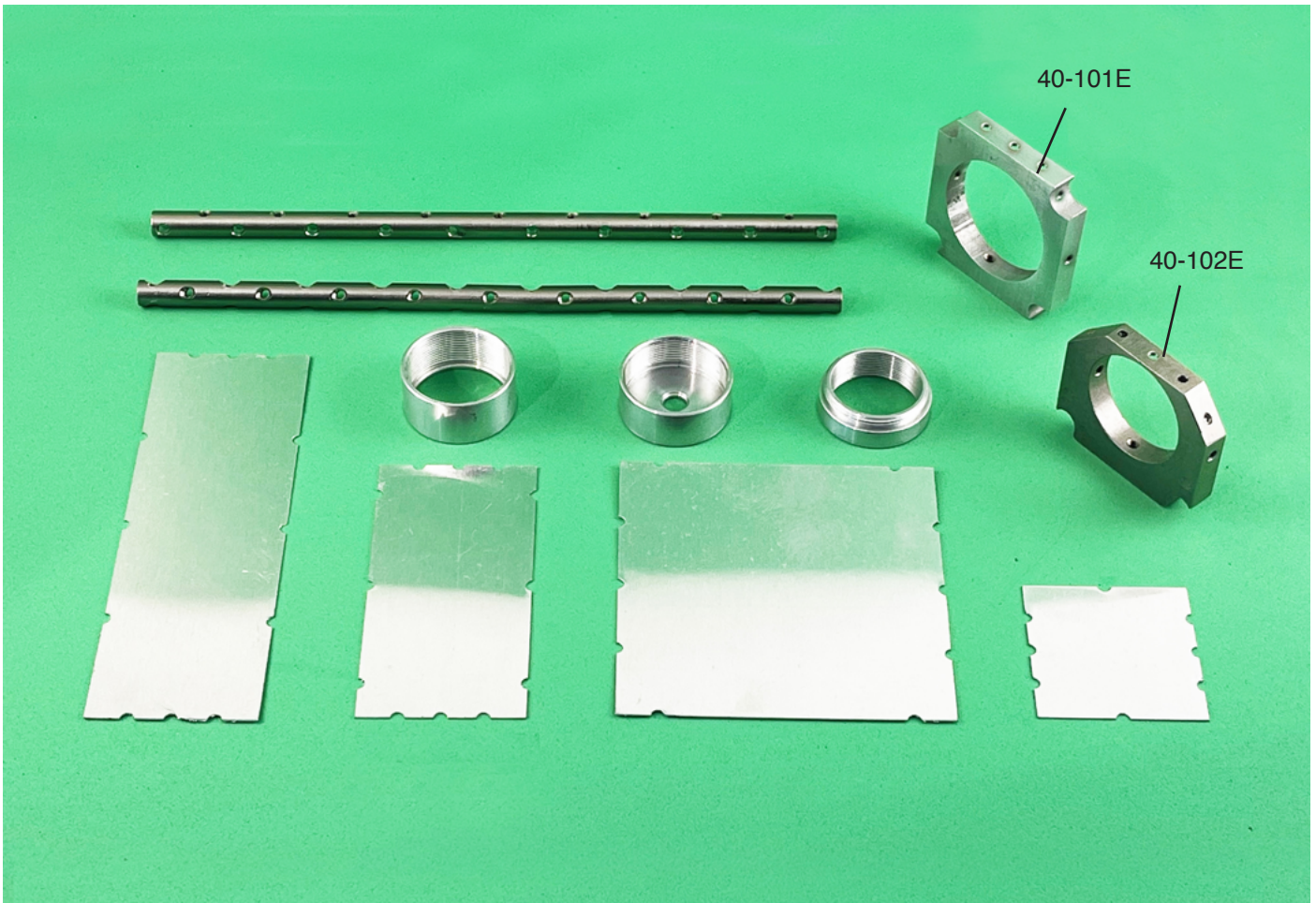

Un anodized Optoform 40E parts are ideal for electronics projects in need of adequate housing. Sheet metal covers may be drilled, crimped to mounts rotary switches, toggle switches, and volume controls. The end result may be anodized, and laser engraved for professional looking Products. Optoelectronics R&D labs have never had such versatile option.

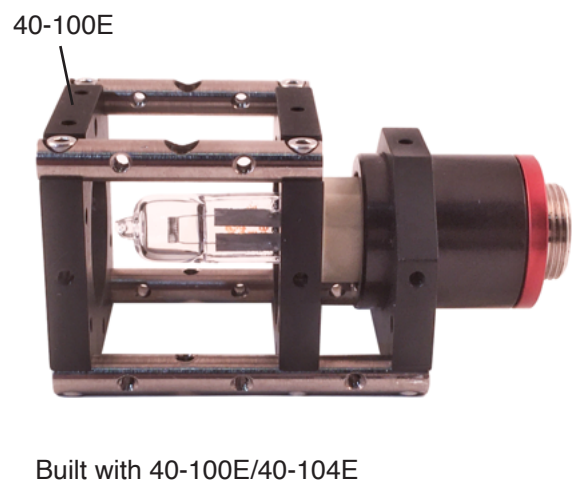
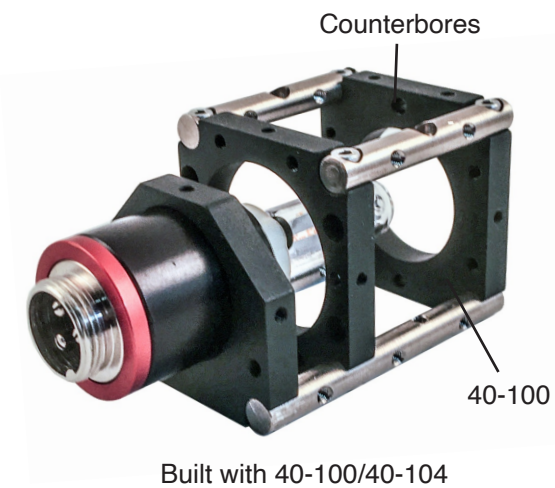

Two examples of a Halogen light box built with Optoform 40, and 40E mounts. In this arrangement, the lamp's filament is aligned with the 25 mm center bore by shifting its socket back and forth. Standard 40-100 mounts have counterbores on their faces that allows face to face mounting. As you could see, the counterbored pattern of 40-100 is not being utilized in this assembly.